

TECHNICAL MANUAL

UNIT, INTERMEDIATE DIRECT
SUPPORT

INTRODUCTION	1-1
--------------	-----

AND INTERMEDIATE GENERAL
SUPPORT
MAINTENANCE INSTRUCTIONS

UNIT MAINTENANCE INSTRUCTIONS	2-1
----------------------------------	-----

INTERMEDIATE DIRECT SUPPORT MAINTENANCE INSTRUCTIONS	3-1
---	-----

BOW ANCHOR WINDLASS
SUBSYSTEM

INTERMEDIATE GENERAL SUPPORT MAINTENANCE INSTRUCTIONS	4-1
--	-----

FOR

APPENDIXES	A-1
------------	-----

LANDING CRAFT UTILITY (LCU)

ALPHABETICAL INDEX	INDEX-1
-----------------------	---------

NSN 1905-01-154-1191

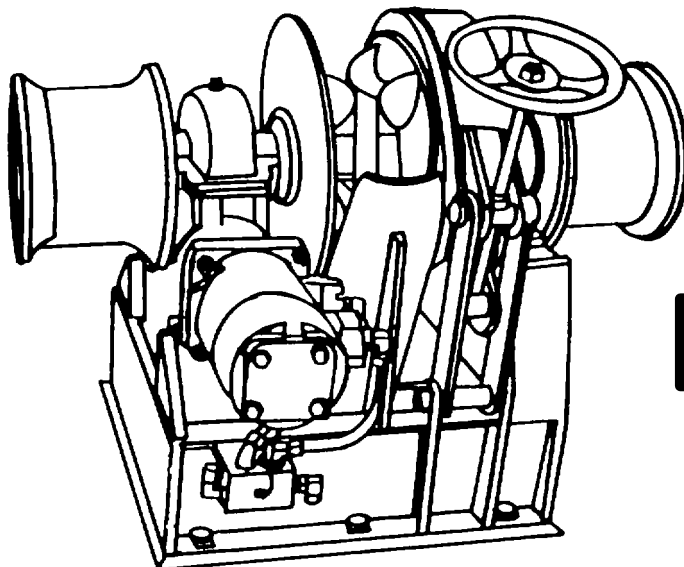

This copy is a reprint which includes current

Approved for public release. Distribution is unlimited.

CHANGE
NO. 3

HEADQUARTERS
DEPARTMENT OF THE ARMY
WASHINGTON, D.C., 30 JUNE 1994

Unit, Intermediate Direct Support and Intermediate General Support
Maintenance Instructions

**BOW ANCHOR WINDLASS SUBSYSTEM
FOR
LANDING CRAFT UTILITY (LCU)
NSN 1905-01-154-1191**

DISTRIBUTION STATEMENT A: Approved for public release; distribution is unlimited.

TM 55-1905-223-24-15, 17 January 1989, is changed as follows:

1. Remove and insert pages as indicated below. New or changed text material is indicated by a vertical bar in the margin. An illustration change is indicated by a miniature pointing hand.

Remove pages

Insert pages

i and ii
B-1 through B-9/
(B-10 blank)

i and ii
B-1 through B-8

2. Retain this sheet in front of manual for reference purposes.

By Order of the Secretary of the Army:

GORDON R. SULLIVAN
General, United States Army
Chief of Staff

Official:

MILTON H. HAMILTON
Administrative Assistant to the
Secretary of the Army
07046

DISTRIBUTION:

To be distributed in accordance with DA Form 12-25-E, block No. 4811, requirements for TM 55-1905-223-24-15.

CHANGE

NO. 2

HEADQUARTERS
DEPARTMENT OF THE ARMY
WASHINGTON, D.C., 28 May 1993

Unit, Intermediate Direct Support and Intermediate General Support
Maintenance Instructions

**BOW ANCHOR WINDLASS SUBSYSTEM
FOR
LANDING CRAFT UTILITY (LCU)
NSN 1905-01-154-1191**

DISTRIBUTION STATEMENT A: Approved for public release; distribution is unlimited

TM 55-1905-223-24-15, 17 January 1989, is changed as follows:

1. Remove and insert pages as indicated below. New or changed text material is indicated by a vertical bar in the margin. An illustration change is indicated by a miniature pointing hand.

Remove page	Insert pages
1-3 and 1-4	1-3 and 1-4

2. Retain this sheet in front of manual for reference purposes.

By Order of the Secretary of the Army:

Official:

MILTON H. HAMILTON
*Administrative Assistant to the
Secretary of the Army*
04413

GORDON R. SULLIVAN
*General, United States Army
Chief of Staff*

DISTRIBUTION:

To be distributed in accordance with DA Forms 12-25-E, block No. 4811, requirements for TM 55-1905-223-24-15.

CHANGE

NO. 1

HEADQUARTERS
DEPARTMENT OF THE ARMY
WASHINGTON, D.C., 22 May 1991

Unit, Intermediate Direct Support and Intermediate General Support
Maintenance Instructions

**BOW ANCHOR WINDLASS SUBSYSTEM
FOR
LANDING CRAFT UTILITY (LCU)
NSN 1905-01-154-1191**

Approved for public release; distribution is unlimited

TM 55-1905-223-24-15, 17 January 1989 is changed as follows:

1. Remove and insert pages as indicated below. New or changed text material is indicated by a vertical bar in the margin. An illustration change is indicated by a miniature pointing hand.

Remove pages

2-9 and 2-10
2-19 and 2-20
4-5 and 4-6
4-33 and 4-34
4-37 and 4-38
4-43 and 4-44
B-5 through B-9/(B-10 blank)

Insert pages

2-9 and 2-10
2-19 and 2-20
4-5 and 4-6
4-33 and 4-34
4-37 and 4-38
4-43 and 4-4
B-5 through B-9/(B-10 blank)

2. Retain this sheet in front of manual for reference purposes.

By Order of the Secretary of the Army:

CARL E. VUONO
General, United States Army
Chief of Staff

Official:

THOMAS F. SIKORA
Brigadier General, United States Army
The Adjutant General

DISTRIBUTION:

To be distributed in accordance with DA Form 12-25E, (qty rqr block No. 4811).

WARNING

MODIFICATION HAZARD

Unauthorized modifications, alterations or installations of or to this equipment are prohibited and are in violation of AR 750-10. Any such unauthorized modifications, alterations or installations could result in death, injury or damage to the equipment.

**HIGH PRESSURE
HYDRAULIC SYSTEM HAZARDS**

Hydraulic systems can cause serious injuries if high pressure lines or equipment fail.

Never work on hydraulic systems or equipment unless there is another person nearby who is familiar with the operation and hazards of the equipment, and who can give first aid. A second person should stand by controls to turn off hydraulic pumps in an emergency. When the technicians are aided by the operators, the operators must be warned about dangerous areas.

MOVING MACHINERY HAZARDS

Be very careful when operating or working near moving machinery.

For Artificial Respiration, refer to FM 21-11.

a/(b blank)

**UNIT, INTERMEDIATE DIRECT SUPPORT
AND INTERMEDIATE GENERAL SUPPORT
MAINTENANCE INSTRUCTIONS**

**BOW ANCHOR WINDLASS SUBSYSTEM
FOR**

**LANDING CRAFT UTILITY (LCU)
NSN 1905-01-154-1191**

REPORTING ERRORS AND RECOMMENDING IMPROVEMENTS

You can help improve this manual. If you find any mistakes or if you know of a way to improve these procedures, please let us know. Mail your letter or DA Form 2028 (Recommended Changes to Publications and Blank Forms), or DA Form 2028-2 located in the back of this manual directly to: Commander, US Army Aviation and Troop Command, ATTN: AMSAT-1-MP, 4300 Goodfellow Blvd., St. Louis, MO 63120-1798. A reply will be furnished directly to you.

DISTRIBUTION STATEMENT A: Approved for public release; distribution is unlimited.

TABLE OF CONTENTS

	<u>PAGE</u>
CHAPTER 1 INTRODUCTION	1-1
Section I General Information	1-1
Section II Equipment Description and Data	1-3
Section III Principles of Operation	1-5
CHAPTER 2 UNIT MAINTENANCE INSTRUCTIONS	2-1
Section I Repair Parts; Special Tools; Test, Measurement, and Diagnostic Equipment (TMDE); and Support Equipment	2-1
Section II Service Upon Receipt	2-1
Section III Unit Preventive Maintenance Checks and Services (PMCS)	2-2
Section IV Unit Maintenance Troubleshooting Procedures.....	2-8
Section V Unit Maintenance Procedures.....	2-10
Section VI Preparation for Storage or Shipment	2-34
CHAPTER 3 INTERMEDIATE DIRECT SUPPORT MAINTENANCE INSTRUCTIONS	3-1

TABLE OF CONTENTS - Continued

CHAPTER 4	INTERMEDIATE GENERAL SUPPORT MAINTENANCE INSTRUCTIONS	4-1
Section I	Repair Parts; Special Tools; Test, Measurement, and Diagnostic Equipment (TMDE); and Support Equipment.....	4-1
Section II	Service Upon Receipt	4-1
Section III	Intermediate General Support Preventive Maintenance Checks and Services (PMCS)	4-2
Section IV	Intermediate General Support Troubleshooting Procedures	4-2
Section V	Intermediate General Support Maintenance Procedures	4-5
Section VI	Preparation for Storage or Shipment	4-50
APPENDIX A	REFERENCES	A-1
APPENDIX B	MAINTENANCE ALLOCATION CHART	B-1
APPENDIX C	EXPENDABLE/DURABLE SUPPLIES AND MATERIALS LIST	C-1
APPENDIX D	TORQUE VALUES	D-1
GLOSSARY	ABBREVIATIONS AND DEFINITIONS	Glossary 1
ALPHABETICAL INDEX		Index 1

CHAPTER 1

INTRODUCTION

	<u>Page</u>
Section I. General Information.....	1-1
Section II. Equipment Description and Data.....	1-2
Section III. Principles of Operation	1-3

Section I. GENERAL INFORMATION

1-1. **Scope.** The scope of this manual is as follows:

- a. Type of Manual. Unit, intermediate direct support, and intermediate general support maintenance manual.
- b. Model Number and Equipment Name. Model MSW-112-TH, Bow Anchor Windlass.
- c. Purpose of Equipment. Used to raise and lower the bow anchors and stud link chain.

1-2. **Maintenance Forms, Records, and Reports.** Department of the Army forms and procedures used for equipment maintenance are those prescribed by DA Pam 738-750, the Army Maintenance Management System.

1-3. **Destruction of Army Materiel.** Refer to TM 750-244-3 for instructions covering the destruction of Army materiel to prevent enemy use.

1-4. **Reporting Equipment Improvement Recommendations (EIR).** If your equipment needs improvement, let us know. Send us an EIR. You, the user, are the only one who can tell us what you don't like about your equipment. Let us know why you don't like the design. Put it on an SF 368 (Quality Deficiency Report). Mail it to: Commander, U S. Army Troop Support Command; ATTN: AMSTR-QX; 4300 Goodfellow Blvd.; St. Louis, Missouri 63120-1798. We'll send you a reply.

1-5. **Preparation for Storage or Shipment.** Administrative storage of equipment issued to and used by Army activities will have preventive maintenance performed in accordance with the Preventive Maintenance Checks and Services (PMCS) charts before storing. When removing the equipment from administrative storage, the PMCS should be performed to assure operational readiness. Repacking of equipment for shipment or short term storage is covered in paragraph 2-21.

Section II. EQUIPMENT DESCRIPTION AND DATA

1-6. **Characteristics, Capabilities, and Features.** A very broad view of the bow anchor windlass is as follows:

a. Characteristics.

- (1) Controlled by two electro hydraulically driven anchor windlasses.
- (2) Each fitted with gypsy heads/cathead warping drums.
- (3) Each windlass has its own power unit.

b. Capabilities and Features.

- (1) Retrieval of anchor chain to chain locker.
- (2) Distribution of anchor chain from chain locker.
- (3) Allows free movement of wildcat, allowing rapid, uncontrolled release of the anchor.

1-7. **Location and Description of Major Components.** The model MSW-112-TH bow anchor windlass (FIGURE 1-1) is a hydraulically driven chain windlass for handling the vessel's bow anchors and stud link chain. Each windlass has a single wildcat and two catheads and its own power unit.

- a. Anchor Windlass Assembly. Two electrohydraulically driven anchor windlasses are provided for the bow anchors, one port and one starboard. The windlasses are controlled at each unit. The windlasses are fitted with gypsy heads/cathead warping drums (1) on each end and one wildcat (3) on the main horizontal shaft.
- b. Anchor Windlass Hydraulic Power System. The anchor windlass hydraulic power system (FIGURE 1-2) consists of the hydradyne-hydraulic power pack assembly.
- c. Failsafe Brake System. The failsafe brake system (5, FIGURE 1-1) is spring loaded to apply the brake. Hydraulic pressure is required to release or "hold off" the brake. Normal operation is to have the brake pressurized in the released position with the hydraulic system running. Any malfunction which reduces the hydraulic system pressure below the release pressure of the brake will cause a brake application.
- d. Gear Box Assembly. Provides the necessary gear reduction between the wildcat/cathead and the hydraulic motor (4, FIGURE 1-1).
- e. Hand Brake. Provides manually operated braking device for the windlass assembly (2, FIGURE 1-1).
- f. Hydraulic Motor. Provides drive to the gear box assembly (6, FIGURE 1-1).
- g. Cathead. Provides hauling capability independent of the anchor operation (1, FIGURE 1-1).

1-8. **Equipment Data.** Characteristics and reference data are provided in Table 1-1. Also see the equipment data given in the operator's manual, TM 55-1905-223-10.

Table 1-1. Equipment Data

Characteristics	Reference Data
<u>Bow Anchor Windlass</u>	<u>Model MSW-112-TH</u>
Rated load	14,000 lb
Brake static hold capacity	140,000 lb
Rate of haul in cathead (gypsy head)	30 ft. per min
Wildcat	26 ft. per min

1-9. **Safety, Care, and Handling.** Safety precautions must be observed at all times while performing maintenance. General WARNINGS and first-aid data appear in the front of this manual. Review all safety information before starting any task. Carefully read through an entire maintenance procedure before performing any maintenance function. Make sure the task can be done safely. All WARNINGS, CAUTIONS, and NOTES are of great importance to your safety and the safety of the equipment.

Section III. PRINCIPLES OF OPERATION

1-10. **General.** The MSW-112-TH bow anchor windlass is a hydraulically driven chain windlass for handling the vessel's bow anchors and stud link chain. The windlass assembly retrieves anchor chain to the chain locker when the anchor is taken in (raised), and distributes anchor chain from the chain locker when the anchor is let down (lowered). It allows free movement of the wildcat when it is necessary to have uncontrolled release of the anchor. Besides the anchor operation, the bow anchor windlass provides hauling capability to provide lifting for other tasks.

PORT ASSEMBLY

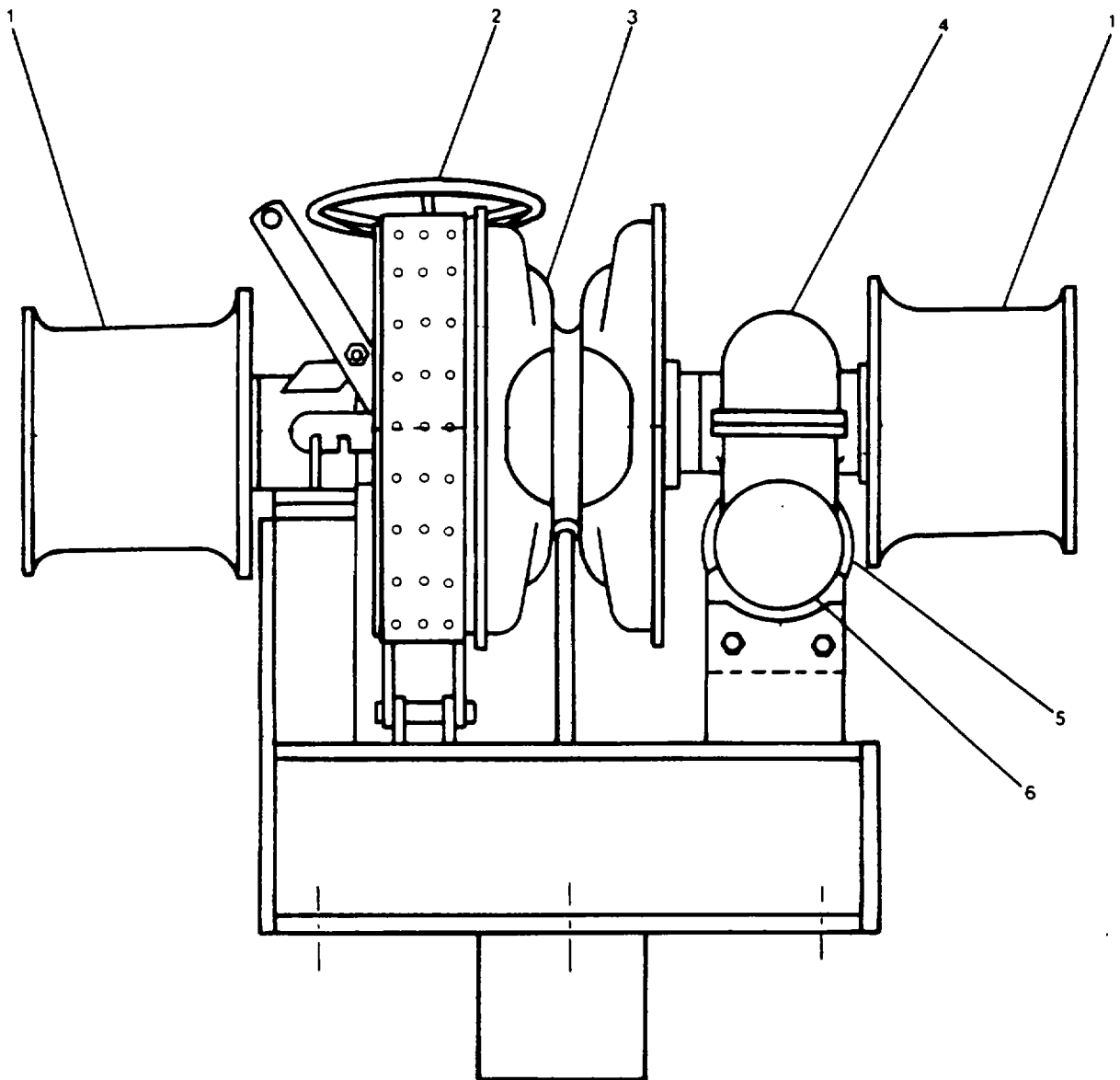

LEGEND:

- 1. CATHEAD (GYPSY HEAD)
- 2. HAND BRAKE
- 3. WILDCAT

- 4. GEAR BOX/OIL FILL
- 5. FAILSAFE BRAKE
- 6. HYDRAUUC MOTOR

FIGURE 1-1. Bow Anchor Windlass Assembly.

☆ GOVERNMENT PRINTING OFFICE: 1993 - 755-028/80261

PIN: 065786-002

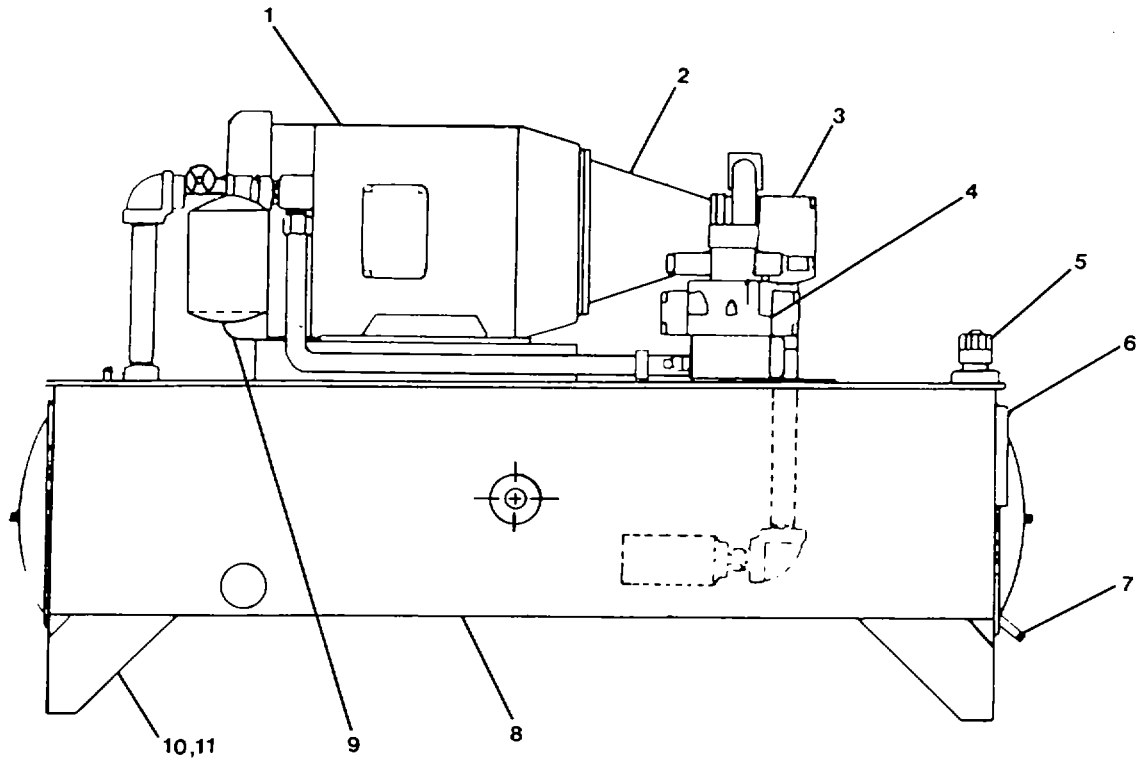

LEGEND

- | | |
|------------------------------|-------------------|
| 1. ELECTRIC MOTOR | 7. DRAIN PLUG |
| 2. COUPLER | 8. RESERVOIR |
| 3. HYDRAULIC PUMP | 9. FILTER ELEMENT |
| 4. DIRECTIONAL CONTROL VALVE | 10. BOLT |
| 5. BREATHER/FILLER | 11. NUT |
| 6. SIGHT LIQUID INDICATOR | |

FIGURE 1-2. Bow Anchor Windlass Hydraulic Power Pack Assembly.

1-5/(1-6 blank)

CHAPTER 2

UNIT MAINTENANCE INSTRUCTIONS

	<u>Page</u>
Section I. Repair Parts, Special Tools; Test, Measurement, and Diagnostic Equipment (TMDE); and Support Equipment	2-1
Section II. Service Upon Receipt	2-1
Section III. Unit Preventive Maintenance Checks and Services (PMCS)	2-2
Section IV. Unit Maintenance Troubleshooting	2-8
Section V. Unit Maintenance Procedures	2-10
Section VI. Preparation for Storage or Shipment	2-34

Section I. REPAIR PARTS, SPECIAL TOOLS; TEST, MEASUREMENT, AND DIAGNOSTIC EQUIPMENT (TMDE); AND SUPPORT EQUIPMENT

2-1. **Common Tools and Equipment.** For authorized common tools and equipment, refer to the Modified Table of Organization and Equipment (MTOE) applicable to your organization.

2-2. **Special Tools, TMDE, and Support Equipment.** Special tools; test, measurement, and diagnostic equipment; and support equipment requirements are listed and illustrated in the Repair Parts and Special Tools List (RPSTL), TM 55-1905-223-24P. These items are also listed in the Maintenance Allocation Chart (MAC), Appendix B of this manual.

2-3. **Repair Parts.** Repair parts are listed and illustrated in the Repair Parts and Special Tools List (RPSTL), TM 55-1905-223-24P.

Section II. SERVICE UPON RECEIPT

2-4. Checking Unpacked Equipment.

- a. Inspect the equipment for damage incurred during shipment. If the equipment has been damaged, report the damage in accordance with the instructions of DA Pam 738-750.
- b. Check the equipment against the packing slip to see if the shipment is complete. Report all discrepancies in accordance the instructions of DA Pam 738-750.
- c. Check to see whether the equipment has been modified.
- d. Remove protective caps, plugs, inserts, wrappings, and tape when inspection/inventory is completed. Inspect piping openings for damage. Wipe off dirt, grease, or protective films at time of installation.

- e. Remove chocks from resilient mounted components.

2-5. **Deprocessing Equipment.** To move windlass assembly, lifting points are indicated in FIGURE 2-1.

WARNING

Lift windlass by lifting points only, using a sling with four legs to prevent tilting or leaning. Keep the sling legs clear of all windlass components when lifting or lowering to prevent damage to equipment or injury to personnel.

2-6. **Preliminary Servicing and Adjustment.** The following procedures should be completed before anchor windlass startup:

- a. Examine windlass and power unit for any obvious problems that might have come up since the last operation.
- b. Check all lubrication points and fluid levels for proper operating levels.
- c. Brake should be screwed down tight.
- d. Clutch should be disengaged and locked.

2-7. **Initial Setup Procedure.** Includes operational checks and inspections that are not performed for a routine startup. Direct support maintenance personnel will perform initial setup in accordance with the operator's manual, TM 55-1905-223-10.

2-8. **Normal Startup.** Refer to the operator's manual, TM 55-1905-223-10.

2-9. **Shutdown Procedure (Usual or Unusual).** Refer to the operator's manual, TM 55-1905-223-10.

Section III. UNIT PREVENTIVE MAINTENANCE CHECKS AND SERVICES (PMCS)

2-10. **Explanation of PMCS Table.** PMCS is designed to keep the equipment in good working condition. This is accomplished by performing certain tests, inspections, and services. Table 2-1 lists items to be serviced and the procedures needed to accomplish the PMCS. The "Interval" column tells you when to perform a check or service. If needed, PMCS may be performed more frequently than the indicated interval. The "Procedures" column tells you how to perform the required checks and services. If your equipment does not perform as required, see Table 2-2, Troubleshooting. Report any malfunctions or failures on DA Form 2404. In the "TM" Number column on DA Form 2404, record the appropriate Item Number from the PMCS table.

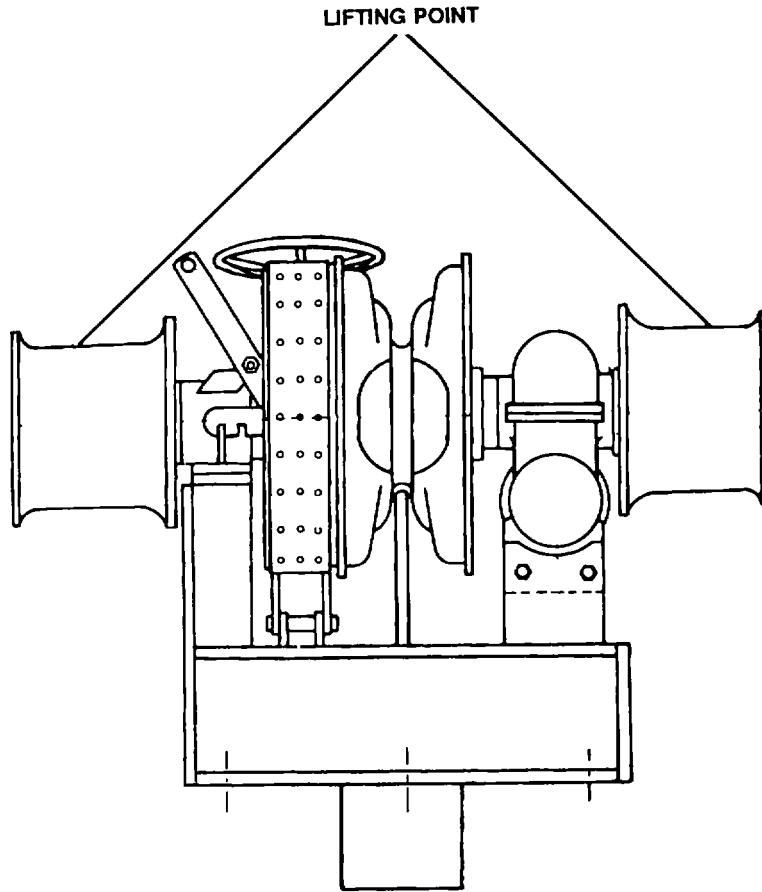

FIGURE 2-1. Windlass Lifting Points.

Table 2-1. Preventive Maintenance Checks and Services

D - Daily W - Weekly M - Monthly Q - Quarterly S - Semiannually A - Annually B - Biennially

Item NO.	Interval							Items to be Checked/ Serviced	Procedures
	D	W	M	Q	S	A	B		
1	•							Gear box	Check oil level. Check for leaks. Lubricate output shaft (LO 55-1905-223-12). Change oil (LO 55-1905-223-12).
2	•							Failsafe brake assembly	Check for leaks.
3	•							Hydraulic motor	Check for leaks.
4	•							Hand brake	Check hydraulic fluid for contaminants and foreign matter.
	•								Check lining to be sure that fasteners holding lining to band are not near the working surface of the lining. If lining is thinner than 3/16 inch of any area, replace lining (para. 4-11).
	•								Check band for any signs of fatigue or cracking.
	•								Check all pins for bending or damage.
	•								Check all cotter pins and/or keepers for bending or fatigue.
5	•							Clutch	Check brake wheel for cracks or looseness.
	•								Lubricate clutch groove (LO 55-1905-223-12).
	•								Check clutch lugs for mashing or rounding.
	•								Check clutch operation assembly.
	•								Check clutch operator nuts.
	•								Actuate clutch in and out several times to check for binding.

Table 2-1. Preventive Maintenance Checks and Services

D - Daily W - Weekly M - Monthly Q - Quarterly S - Semiannually A - Annually B - Biennially

Item NO.	Interval							Items to be Checked/ Serviced	Procedures
	D	W	M	Q	S	A	B		
6	•							Hydraulic power pack assembly	Check for leaks, loose fitting at the hydraulic pump, control valve, and filter head. Check for leaks on all reservoir fittings. Check for corrosion and physical damage.
7	•							Pressure gauge	Check for reading of 2900 psi max with the system operating.
8	•		•					Temperature gauge	Check for reading of 150° maximum with the system operating.
9	•							Fluid level indicator	Check for proper fluid level (full).
10		•						Wildcat	Inspect pockets for any excessive wear which may cause sloppy chain fit. Check bushing for damage. a. Attach dial indicator (2, FIGURE 2-2) between gearbox (3) and wildcat (1).

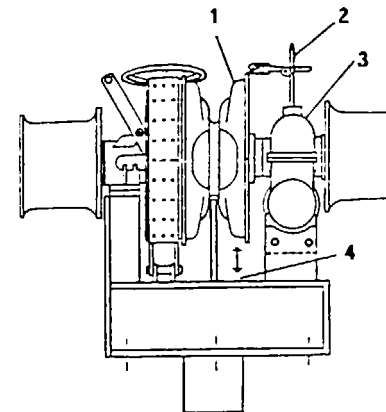

FIGURE 2-2. Wildcat Bushing Check.

Table 2-1. Preventive Maintenance Checks and Services

D - Daily W - Weekly M - Monthly Q - Quarterly S - Semiannually A - Annually B - Biennially

Item NO.	Interval							Items to be Checked/ Serviced	Procedures
	D	W	M	Q	S	A	B		
10								Wildcat - CONT	b. Use pry bar between frame (4) and wildcat (10). c. Pry up and down, measuring any movement in wildcat. d. Movement in excess of .015 inch to .020 inch indicates excessive wear. Replace wildcat bushing (para. 4-11).
11		•						Cat head	Check work in surface for grooves and cracks. Check retainer plate and bolt for looseness.
12		•						Reservoir tank	Drain water accumulation from hydraulic tank. Place 5-gallon container under reservoir drain. Open and drain fluid until only hydraulic fluid is draining. Secure drain, refill, and dispose of water/oil mixture in waste tank (TM 55-1905-223-24-18).
13				•				Return filter	Change return filter element (para. 2-17)
14				•				Drive coupling	Check to see that set screws are secure (para. 2-18).
15				•				Alternating current motor	Check electrical connectors (para. 2-18). Check all areas for corrosion in the electrical junction box. a. Check for voltage at the junction box. b. Check for resistance with a megohmmeter (Item 12, Appendix C).
16					•			Air breather	Lubricate bearing (LO 55-1905-223-24-12). Clean air breather filter with compressed air.
17						•		Suction strainer	Clean suction strainer element (para. 2-17).

Table 2-1. Preventive Maintenance Checks and Services

D - Daily W - Weekly M - Monthly Q - Quarterly S - Semiannually A - Annually B - Biennially

Item NO.	Interval							Items to be Checked/ Serviced	Procedures
	D	W	M	Q	S	A	B		
18			•					Fairlead rollers (deck mounted, directly forward of the outboard cathead)	Check for corrosion or broken parts. Remove corrosion with sandpaper (Item 8, Appendix C). Grease all fittings. Refer to LO 55-1905-223-12.
19	•							Hydraulic pump	Check for fluid leaks. Check the pump body and all fittings and hardware for corrosion or other physical damage.
20	•		•					Directional control valve	Check hydraulic fittings for fluid leaks. Check electrical connections for secureness and chafing. Check control valve body and hardware for corrosion or other physical damage.
21			•					Chain stopper	Check for security, corrosion, or broken parts.
22			•					Bow anchor chain	Check shackle, swivel, and detachable link for metal friction wear, corrosion, or other physical damage. Replace if metal wear exceeds 5% of total metal, or corrosion is deeper than 5% of thickness of part. Using caliper set micrometer, measure outside diameter of part or chain.

Section IV. UNIT MAINTENANCE TROUBLESHOOTING

2-11. **Troubleshooting**. Both a symptom index and a troubleshooting table are provided. The symptom index will help you locate the information you need for troubleshooting.

SYMPTOM INDEX

	Troubleshooting Procedure (Table 2-2)
GEAR BOX	
Overheated	Item 4
HYDRAULIC FAIL-SAFE BRAKE	
Fails	Item 3
HYDRAULIC POWER UNIT	
Fails to pump fluid	Item 2
Fails to start	Item 1
WINDLASS	
Overruns	Item 3

Table 2-2 lists the common fault conditions that may be found during operation or maintenance of the equipment. Look for causes and do corrective actions in the order listed. This manual cannot list every symptom that may show up, and it cannot list all of the possible causes and corrective actions. If a symptom is not listed, or if it keeps up after you have performed the corrective actions, notify your supervisor.

Table 2-2. Unit Maintenance Troubleshooting

MALFUNCTION	TEST OR INSPECTION	CORRECTIVE ACTION
1. Hydraulic power unit fails to start.	STEP 1. Check for power. Reestablish power.	
	STEP 2. Check the dial pressure gage (1) on figure 2-6 for proper indication (green). If in the (red), the filter element (18) should be changed.	
	STEP 3. Check controller pilot circuit fuses (control circuits). Replace fuses if necessary.	
	STEP 4. Check for defective start switch. Replace start switch (TM 55-1905-223-24-18).	
	STEP 5. Check for defective alternating current motor. Replace alternating current motor (para. 2-18).	
2. Hydraulic power unit fails to pump fluid.	STEP 1. Check fluid level. Fill to correct fluid level (para. 2-13; PMCS Item 8).	
	STEP 2. Check for stuck directional control valve. Replace directional control valve (para. 2-20).	
	STEP 3. Check for contaminated fluid. Change fluid (para. 2-13).	
	STEP 4. Check for clogged suction strainer. Remove and clean suction strainer (para. 2-17).	
	STEP 5. Check for defective relief valve. Replace relief valve (para. 2-17).	
	STEP 6. Check for defective hydraulic pump. Replace hydraulic pump (para. 2-19).	
3. Windlass overruns load or hydraulic fail-safe brake fails.	STEP 1. Check for defective directional control valve. Replace hydraulic valve (para. 2-20).	
4. Gear box overheated.	STEP 1. Check for low lubricant level. Correct lubricant level (LO 55-1905-223-12).	

Section V. UNIT MAINTENANCE PROCEDURES

2-12. **General.** This section provides unit maintenance procedures for the bow anchor windlass. The tasks are for removal and replacement of components.

2-13. **Equipment Condition .**

- a. During replace/repair of hydraulic system, all openings should be capped/ plugged to prevent foreign matter or contamination from entering the system.
- b. To perform the following unit maintenance procedures, the chain, windlass, and hydraulic power pack must be placed in the following condition:
 - (1) Chain stoppers (Devil's claw) (1, FIGURE 2-3) in place, securing chain.
 - (2) Secure the windlass hand brake fully by rotating the brake wheel (2, FIGURE 1-1) fully clockwise.

WARNING

Clearly display a tag marked "Out of Service" on the ship's electrical service circuit breaker panel to prevent accidental re-energizing of the circuits that could result in injury or death.

- (3) Remove power from the hydraulic power pack by opening and tagging the vessel's electrical service circuit breakers "Out of Service."
 - (4) Drain the hydraulic fluid from the reservoir of the hydraulic power pack, using a clean 30-gallon container to hold the reservoir contents with no spillover. Fluid may be drained by removing the drain plug, (7, FIGURE 1-2), located beneath the sight/temperature gauge. Be sure to insert and secure the drain plug before refilling reservoir with hydraulic fluid.
- c. Refill hydraulic reservoir and restore electrical power to the power pack upon completion of all unit maintenance procedures.
 - d. Remove "Out of Service" tag.
 - e. Remove chain stoppers (1, FIGURE 2-3) and release hand brake if windlass is required for immediate service.

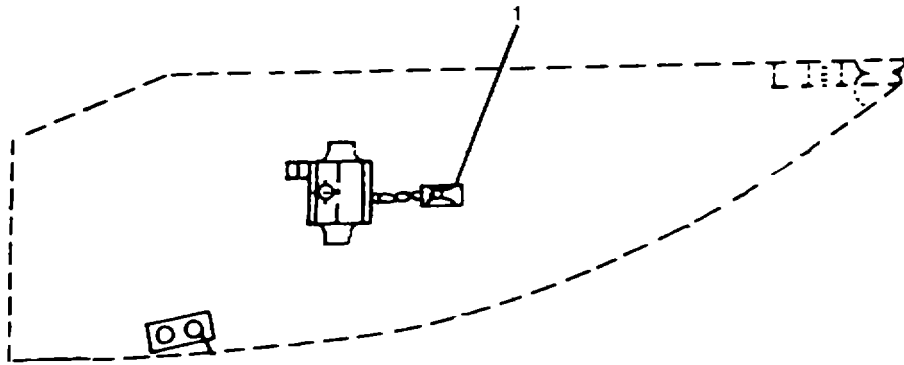

FIGURE 2-3. Bow Anchor Windlass Assembly - Chain Stopper Location.

MAINTENANCE OF BOW ANCHOR WINDLASS SUBSYSTEM

2-14. Replace/Repair Hydraulic Valve. (FIGURE 2-4)

This task covers: a. Removal, b. Repair, c. Replacement.

INITIAL SETUPTools

Tool kit, general mechanic's,
5180-00-699-5273

Materials/Parts

Cartridge P/N CBEH-LJHN
Electrical ID tags, Item 7,
Appendix C
Drain pan, Item 4, Appendix C

Equipment Condition

Windlass inoperative (para. 2-13).
Electrical power removed from
hydraulic power pack and tagged
"Out of Service."

NOTE

Use drain pan to catch fluid from lines.

REMOVAL

- a. Remove cartridges (8).
- b. Disconnect power pack input (1) and output (5) lines.
- c. Disconnect hydraulic motor input (3) and output (4) lines.
- d. Disconnect failsafe brake line (6).
- e. Remove mounting bolts (2).
- f. Remove hydraulic valve (7).

REPAIR

Repair of the hydraulic valve authorized at the unit level is replacement of the cartridges.

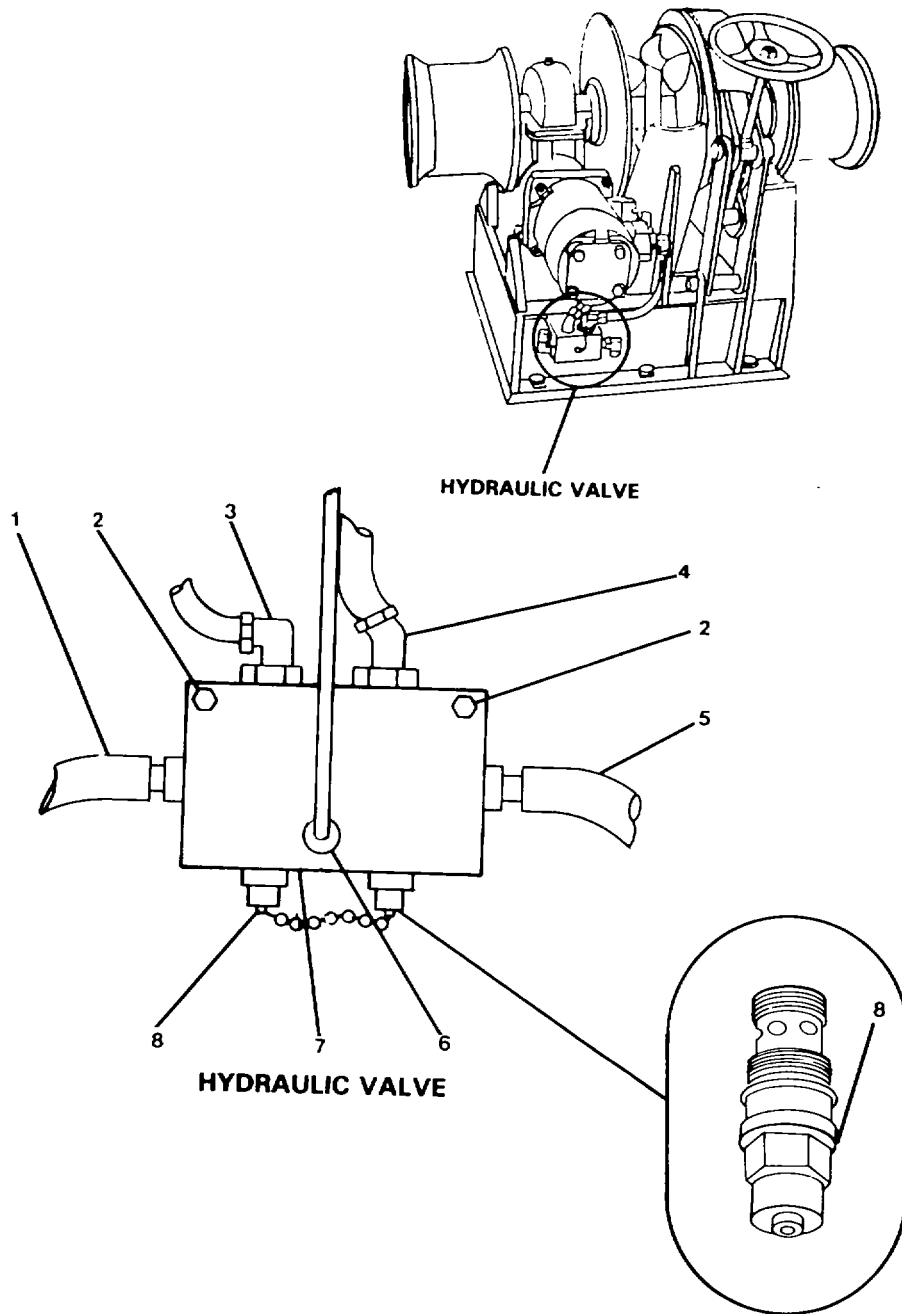

FIGURE 2-4. Hydraulic Valve.

REPLACEMENT

NOTE

If only cartridges (8) were removed, replace cartridges.

- a. Install hydraulic valve (7) and secure with bolts (2).
- b. Install failsafe brake line (6). Replace cartridges (8).
- c. Connect hydraulic motor output (4) and input (3) lines.
- d. Connect power pack output (5) and input (1) lines.

2-15. Replace Failsafe Brake Assembly. (FIGURE 2-5)

This task covers: a. Removal, b. Replacement.

INITIAL SETUP**Tools**

Tool kit, general mechanic's,
5180-00-699-5273
Torque wrench, 5120-01-125-5190

Equipment Condition

Windlass inoperative (para. 2-13)
Electrical power removed from
hydraulic power pack and tagged
"Out of Service."

Materials/Parts

Failsafe brake assembly P/N 37735H
Cap plug, Item 5, Appendix C
Cleaning solvent, Item 6, Appendix C
Electrical ID tags, Item 7, Appendix C

REMOVAL

- a. Remove hydraulic inlet line (7) to brake and install a cap plug.

CAUTION

Do not apply more than 15 psi static air pressure to the brake or damage to the brake could occur.

- b. Apply 15 psi air pressure to hydraulic inlet line fitting on bottom of brake to free braking spring pressure.
- c. Remove two half-inch mounting bolts (6) from brake assembly (4).
- d. Remove brake assembly (4) from hydraulic motor (3).

REPLACEMENT

- a. Clean the brake mounting face with cleaning solvent.
- b. Place the brake shaft into the hydraulic motor (3) with the brake bleeder screw in the vertical position.

CAUTION

Do not apply more than 15 psi static air pressure to the brake or damage to the brake could occur.

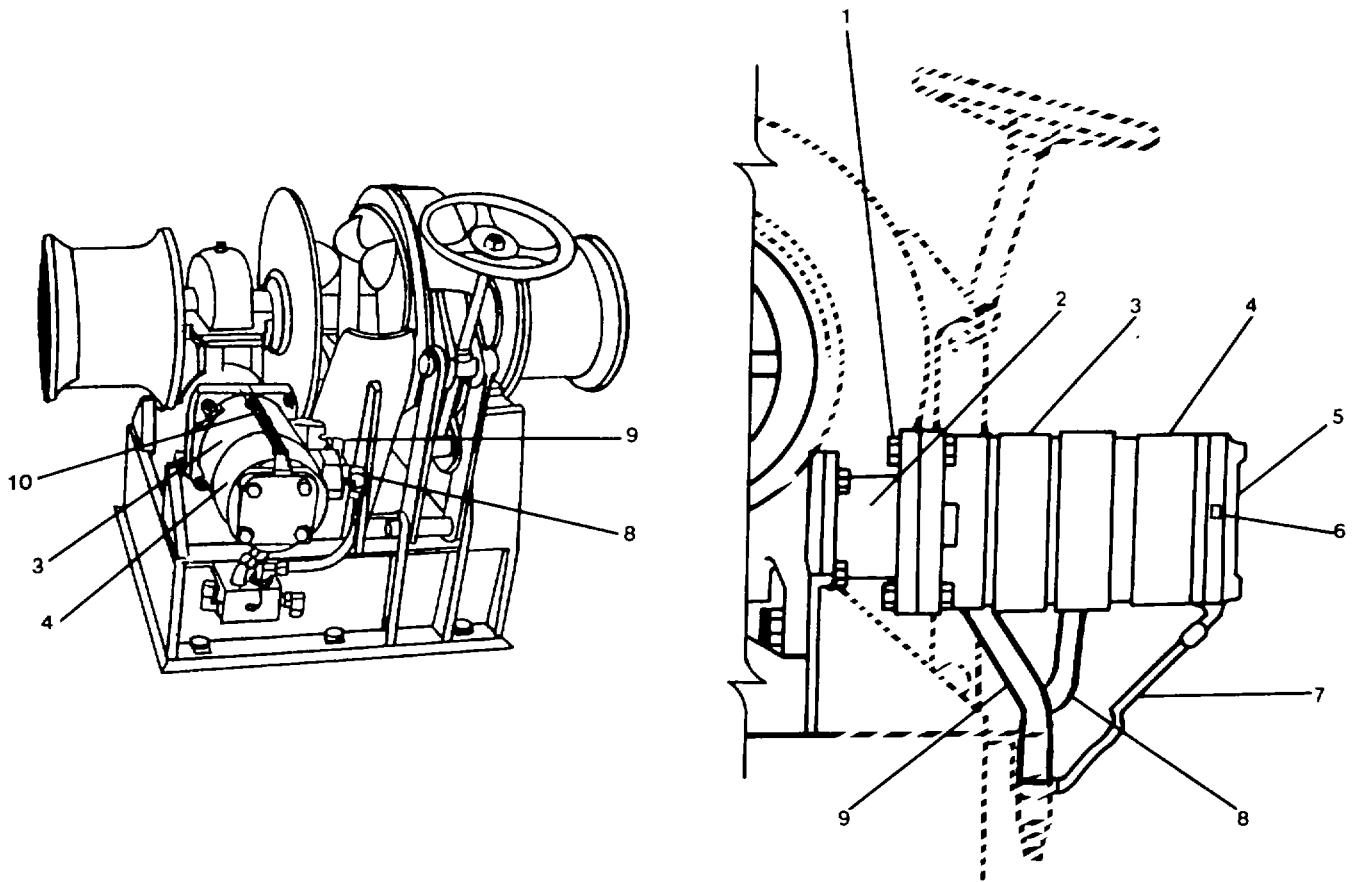

FIGURE 2-5. Failsafe Brake and Hydraulic Motor Assembly.

- c. Apply 15 psi air pressure to the hydraulic inlet line fitting on bottom of brake to free braking spring pressure.
- d. Discontinue air pressure.
- e. Align mounting bolt holes by rotating the brake.

CAUTION

Make sure the mounting bolts are not long enough to bottom out, but of sufficient length to fully thread into the mounting flange holes.

- f. Replace two mounting bolts (6).
- g. Run bolts in alternately until snug to prevent binding, then torque the bolts to 75-85 ft-lb (102-116 N•m).

CAUTION

Both shafts must slide together freely. Do not use bolts to force unit together.

- h. With motor and brake bolted into position, remove cap plug and connect inlet hydraulic line (7) to brake.
- i. Bleed air from brake using bleeder screw.

2-16. **Replace Hydraulic Motor Assembly**. (FIGURE 2-5)

This task covers: a. Removal, b. Replacement.

INITIAL SETUP

Tools

Tool kit, general mechanic's,
5180-00-699-5273

Material/Parts

Hydraulic motor assembly
P/N 037-61-026-040
Electrical ID tags, Item 7,
Appendix C

Equipment Condition

Windlass inoperative (para. 2-13).
Electrical power removed from hydraulic
power pack and tagged "Out of Service."
Failsafe brake assembly removed
(para. 2-15).

REMOVAL

WARNING

The hydraulic motor assembly is heavy. Have two soldiers assist in removal and replacement to prevent dropping the motor.

- a. Disconnect hydraulic hoses (8, 9 and 10) from the side flanges on hydraulic motor (3).
- b. Remove bolts (1) securing motor flange to gear reducer (2).

CAUTION

Separate the hydraulic motor from the gear reducer carefully to prevent damage to the gear teeth.

- c. Remove hydraulic motor (3) from the gear reducer (2).

REPLACEMENT

- a. Replace hydraulic motor (3) to gear reducer (2).
- b. Secure hydraulic motor with bolts (1).

- c. Reconnect hydraulic hoses (8, 9 and 10) to the hydraulic motor (3).
- d. Replace failsafe brake assembly, paragraph 2-15.
- e. Restore windlass to operating condition, paragraph 2-13.
- f. Operate the windlass and check for proper operation.

2-17. **Repair Hydraulic Power Pack Assembly.** (FIGURE 2-6)

This task covers: a. Removal, b. Repair, c. Replacement.

INITIAL SETUP

Tools

Tool kit, general mechanic's,
5180-00-699-5273
Lifting sling P/N 3375957

Materials/parts

Hydraulic power pack assembly
P/N 07-0085
Fluid filter head
P/N SF-120-25-3
Filter element P/N SE-10
Relief valve P/N RV2-10
Reservoir heater
P/N ARMTO-500TH
Breather P/N HC-120
Suction strainer P/N SS-150-3
Inspection cover gasket P/N HH80-3786-2
Liquid sight indicator P/N HSG-55
Dial pressure gauge P/N 25-310-0-5000
Cleaning solvent, Item 6, Appendix C
Electrical ID tags, Item 7, Appendix C
Wiping rags, Item 1, Appendix C

Equipment Condition

Windlass inoperative (para. 2-13).
Electrical power removed from
hydraulic power pack and tagged
"Out of Service."
Reservoir drained (para. 2-13).

General Safety Instruction

Make sure that at least two soldiers
are available to lift the
hydraulic power pack assembly
components.

REMOVAL

a. Remove Inspection Cover and Gasket.

- (1) Remove center attaching bolts (8) securing the reservoir inspection covers (9), right and left sides.
- (2) Remove inspection cover gaskets (10) and discard.
- (3) Thoroughly clean all gasket material from the mating surfaces of covers and reservoir using solvent and wiping rags.

b. Remove Fluid Filter Head and Dial Pressure Gauge.

- (1) Unscrew filter element (18) from head (2) and discard.

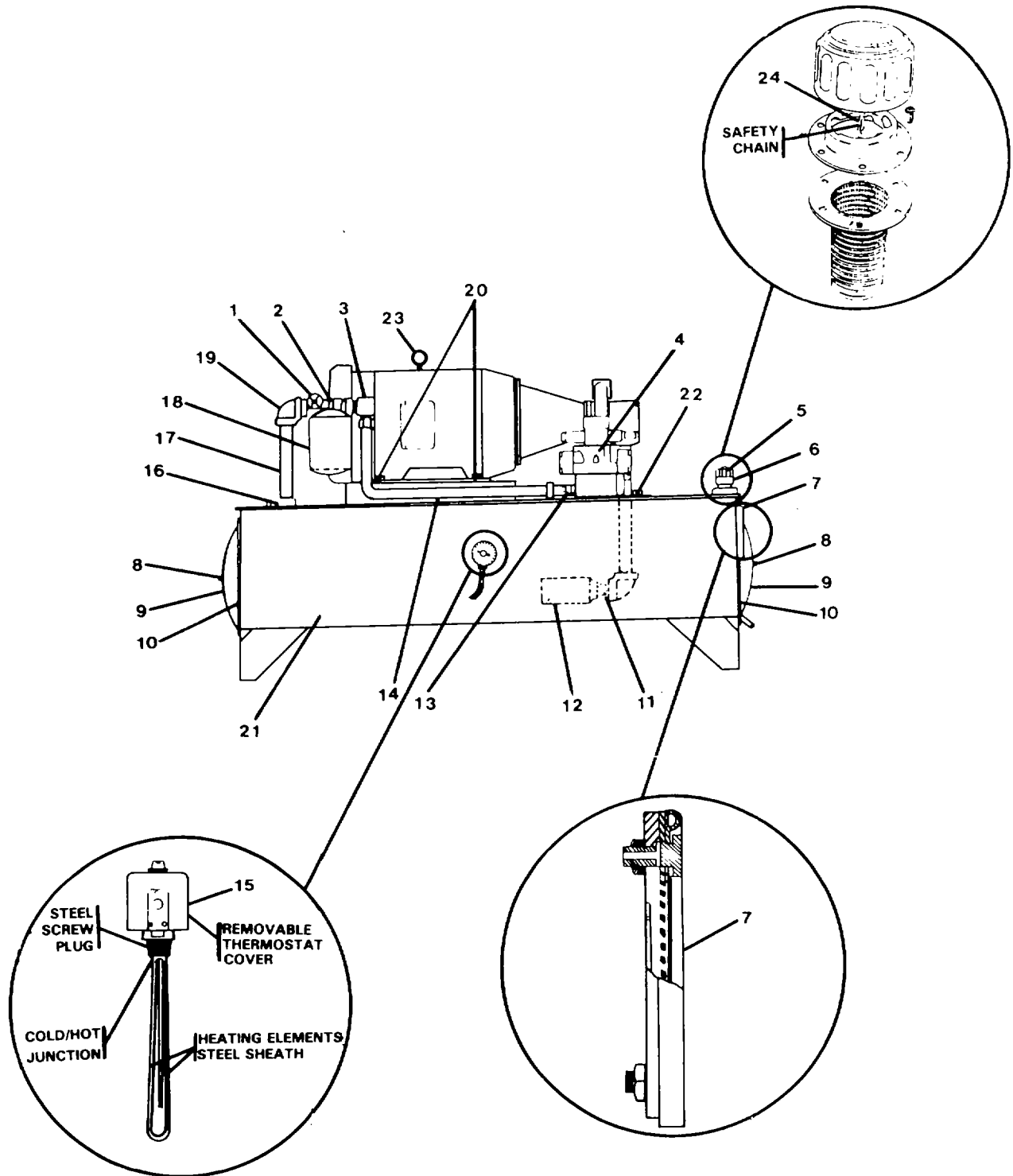

FIGURE 2-6. Hydraulic Power Pack Assembly.

- (2) Disconnect the relief valve hydraulic line (14) from coupling (3).
- (3) Remove dial pressure gauge (1).
- (4) Loosen retaining nut (16).
- (5) Unscrew pipe (17) from elbow (19) and remove pipe.
- (6) Unscrew elbow (19) from head (2) and remove elbow.
- (7) Remove head (2) from coupling (3).

c. Remove Relief Valve.

- (1) Disconnect the relief valve hydraulic line (14) from relief valve (13).
- (2) Unscrew the relief valve (13) from the control valve (4).
- (3) Remove relief valve.

d. Remove Suction Strainer.

- (1) Remove suction strainer (12) from coupler (11).
- (2) Check strainer for oil sludge deposits or other contamination. Clean as required using cleaning solvent.

e. Remove Reservoir Heater.

- (1) Remove the thermostat cover from the heater assembly.
- (2) Disconnect and tag electrical power connections to reservoir heater (15).
- (3) Remove reservoir heater by turning the steel screw connector counter-clockwise (see detail).
- (4) Check heater elements for oil sludge or other contamination. Clean as required using cleaning solvent.

f. Remove Breather.

- (1) Remove breather.
- (2) Disconnect safety chain securing the breather (5).
- (3) Replace breather if dirty.
- (4) Clean the breather thoroughly wiping with clean wiping rags.

g. Remove Liquid Sight Indicator.**CAUTION**

Be careful not to crack sight gauge when removing to avoid leaks.

- (1) Remove connections securing the liquid sight indicator (7) (see detail).
- (2) Remove indicator.

WARNING

The hydraulic power pack is very heavy. Make sure at least two soldiers are available.

h. Remove Hydraulic Power Pack Assembly (Pump/Motor Assembly).

- (1) Tag and disconnect electrical power connections to the power pack assembly.
- (2) Remove four motor mounting bolts (20) and four suction flange bolts (22) securing the pump/motor assembly to reservoir.
- (3) Remove discharge piping from the pump.
- (4) Attach lifting sling to lifting eye (23) on the motor and lift the pump/motor assembly clear of the reservoir.

REPAIR

Repair of the hydraulic power pack authorized at unit level is replacement of the hydraulic power pack assembly, fluid filter head, filter element, relief valve, reservoir heater, breather, suction strainer, inspection cover gaskets, dial pressure gauge, and liquid sight indicator.

REPLACEMENTa. Replace Hydraulic Power Pack Assembly.

- (1) Using a lifting sling, position the pump/motor assembly to the mounting pads or the reservoir.
- (2) Install four motor mounting bolts (20) and four suction flange bolts (22) to secure the pump/motor assembly to reservoir.
- (3) Connect pump discharge piping.
- (4) Remove lifting sling.

(5) Reconnect electrical power connections to the ac motor, and remove tags.

b. Install Liquid Sight Indicator.

CAUTION

Be careful not to crack sight gauge when reassembling to avoid leaks.

(1) Position liquid sight indicator (7) to the mounting holes on the reservoir.

(2) Secure indicator with attaching connectors. (See detail, FIGURE 2-6).

c. Install Breather.

(1) Connect safety chain (24) securing the breather. (See detail, FIGURE 2-6).

(2) Replace breather (5).

d. Install Reservoir Heater.

(1) Replace reservoir heater (15) in reservoir body and secure with attaching hardware.

(2) Remove tags and attach electrical power connections to heater.

(3) Install thermostat cover.

e. Install Suction Strainer. Connect suction strainer (12) to coupler (11).

f. Install Relief Valve.

(1) Replace relief valve (13).

(2) Secure relief valve to the control valve (4).

(3) Connect relief valve hydraulic line (14).

g. Install Fluid Filter Head and Dial Pressure Gauge.

CAUTION

Securing the filter element too hard could result in warping the filter gasket, causing fluid leaks. Do not secure filter more than procedure calls for.

(1) Screw pipe (17) into retaining nut (16).

(2) Screw elbow (19) onto pipe (17).

(3) Attach dial pressure gauge (1).

- (4) Attach fluid filter head (2) to coupling (3).
- (5) Connect the relief valve hydraulic line (14) to the coupling (3).
- (6) Screw filter element (18) onto head (2). Secure 1/2 turn after gasket on filter contacts filter body.

h. Install Inspection Cover and Gasket.

- (1) Replace the inspection cover gaskets (10) to the reservoir, right and left sides.
- (2) Replace the inspection cover (9), right and left sides, and secure with attaching bolts (8).

i. Operational Check.

- (1) Refill hydraulic reservoir, paragraph 2-13.
- (2) Restore electrical power to hydraulic power pack assembly and remove tags.
- (3) Operate the windlass and check for proper operation, paragraph 2-13. Check for leaks.

2-18. **Replace Alternating Current Motor.** (FIGURE 2-7)

This task covers: a. Removal, b. Replacement.

INITIAL SETUP

Tools

Tool kit, general mechanic's,
5180-00-699-5273
Lifting sling P/N 3375957

Materials/Parts

Alternating current motor
P/N 10J98Z65-286TC
Wiping rags, Item 1, Appendix C
Electrical ID Tags, Item 7,
Appendix C

Equipment Condition

Windlass inoperative (para. 2-13).
Electrical power removed from
hydraulic power pack and tagged
"Out of Service."
Reservoir drained (para. 2-13).
Hydraulic power pack assembly
(pump/motor assy.) removed (para.
2-17).

General Safety Instruction

Don't touch power cables with the
sling.

WARNING

Alternating current motor is heavy. Use a lifting sling and lifting fixture to remove and replace the motor or serious personal injury may occur.

CAUTION

The spline teeth on the pump shaft may be damaged by careless handling. Remove and replace flexible shaft coupling carefully.

NOTE

Access to the flexible shaft coupling is through an inspection hole in the bottom of the C-face adapter between the pump and motor.

REMOVAL

- a. Gaining access through C-face adapter (4) bottom opening, loosen four hex screws (2) securing flexible shaft coupling (3) to pump (5) and motor (1) shafts.

- b. Remove hardware securing C-face adapter (4) to motor (1).
- c. Attach lifting sling to motor (1) at eye bolt (6).
- d. Separate motor (1) from hydraulic pump (5) by pulling motor and pump apart. The two parts of flexible shaft coupling (3) will separate.
- e. Remove motor.

REPLACEMENT

- a. Align motor (1) and one part of flexible shaft coupling (3) on motor shaft to pump (5) and other part of flexible shaft coupling (3). Secure coupling to shafts with four hex screws (2).
- b. Secure C-face adapter (4) to motor (1) with mounting hardware.
- c. Replace hydraulic pump/motor assembly, paragraph 2-17.
- d. Fill reservoir, paragraph 2-13.
- e. Connect electrical power to windlass, restore windlass to operation, paragraph 2-13.

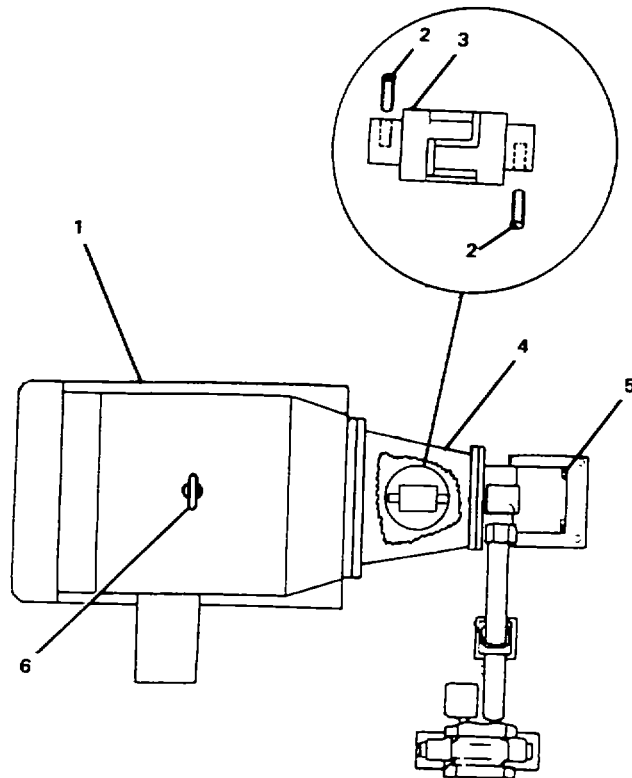

FIGURE 2-7. Alternating Current Motor.

2-19. **Replace Hydraulic Pump.** (FIGURE 2-8)

This task covers: a. Removal, b. Replacement.

INITIAL SETUP

Tools

Tool kit, general mechanic's,
5180-00-699-5273

Materials/Parts

Hydraulic pump
P/N T6C-014-1-01-B1
Wiping rags, Item 1, Appendix C
Electrical ID tags,
Item 7, Appendix C

Equipment Condition

Windlass inoperative (para. 2-13).
Electrical power removed from
hydraulic power pack and tagged
"Out of Service."
Reservoir drained (para. 2-13)
Hydraulic power pack assembly
(pump/motor assy.) removed (para.
2-17).
Alternating current motor separated
from hydraulic pump (para. 2-18).

CAUTION

The spline teeth on the pump shaft may be damaged by careless handling. Remove and replace pump carefully.

REMOVAL

- a. Remove hydraulic line (1) from the control valve and hydraulic pump (2).
- b. Remove four bolts (3), bottom of pump, securing pump to reservoir hydraulic line flange (4).
- c. Remove hydraulic pump (2).

REPLACEMENT

CAUTION

The spline teeth on the pump shaft may be damaged by careless handling. Remove and replace pump carefully.

- a. Replace hydraulic pump.
- b. Install four bolts (3) that secure pump to reservoir hydraulic line flange (4).

- c. Connect hydraulic line (1) to the control valve and pump (2).
- d. Connect ac motor to hydraulic pump, paragraph 2-18.
- e. Replace hydraulic power pack assembly, paragraph 2-17.
- f. Fill reservoir, paragraph 2-13.
- g. Connect electrical power and check for proper operation.

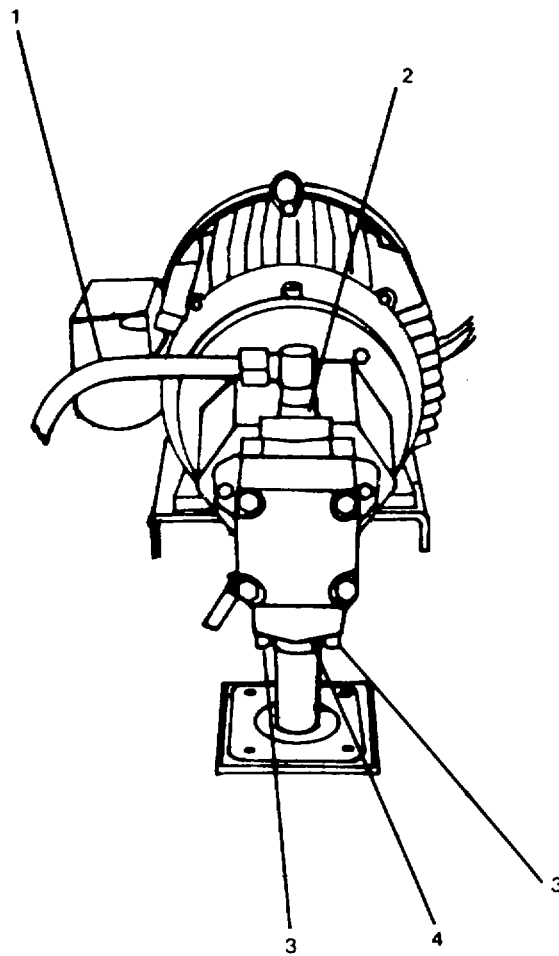

FIGURE 2-8. Hydraulic Pump.

2-20. Replace Directional Control Valve. (FIGURE 2-9)

This task covers: a. Removal, b. Replacement.

INITIAL SETUPTools

Tool kit, general mechanic's,
5180-00-699-5273

Materials/Parts

Directional control valve
P/N A3D03-33-B01-03-A-14CS
Wiping rags, Item 1, Appendix C
Electrical ID tags, Item 7,
Appendix C

Equipment Condition

Windlass inoperative (para. 2-13).
Electrical power removed from
hydraulic power pack and tagged
"Out of Service."

REMOVAL**WARNING**

Do not attempt the following procedure on a pressurized system. Escaping pressurized hydraulic fluid can cause serious personal injury.

CAUTION

During replacement of directional control valve, all openings should be covered to prevent foreign matter or contaminants from entering the system.

- a. Disconnect pipe fittings from part A (15) and part B (14) on subplate (16).
- b. Disconnect couplers (1 and 3) from fittings (2 and 4).
- c. Disconnect fitting (2) from directional control valve (12).
- d. Disconnect pipe nipple (5) and fitting (4) from directional control valve (12).
- e. Remove machine screws (6) securing symbol plate (7) and preformed packing (8) to wiring box (10). Remove symbol plate (7) and preformed packing (8).
- f. Inside wiring box (10), tag and disconnect electrical wire connections to electrical solenoid (11).

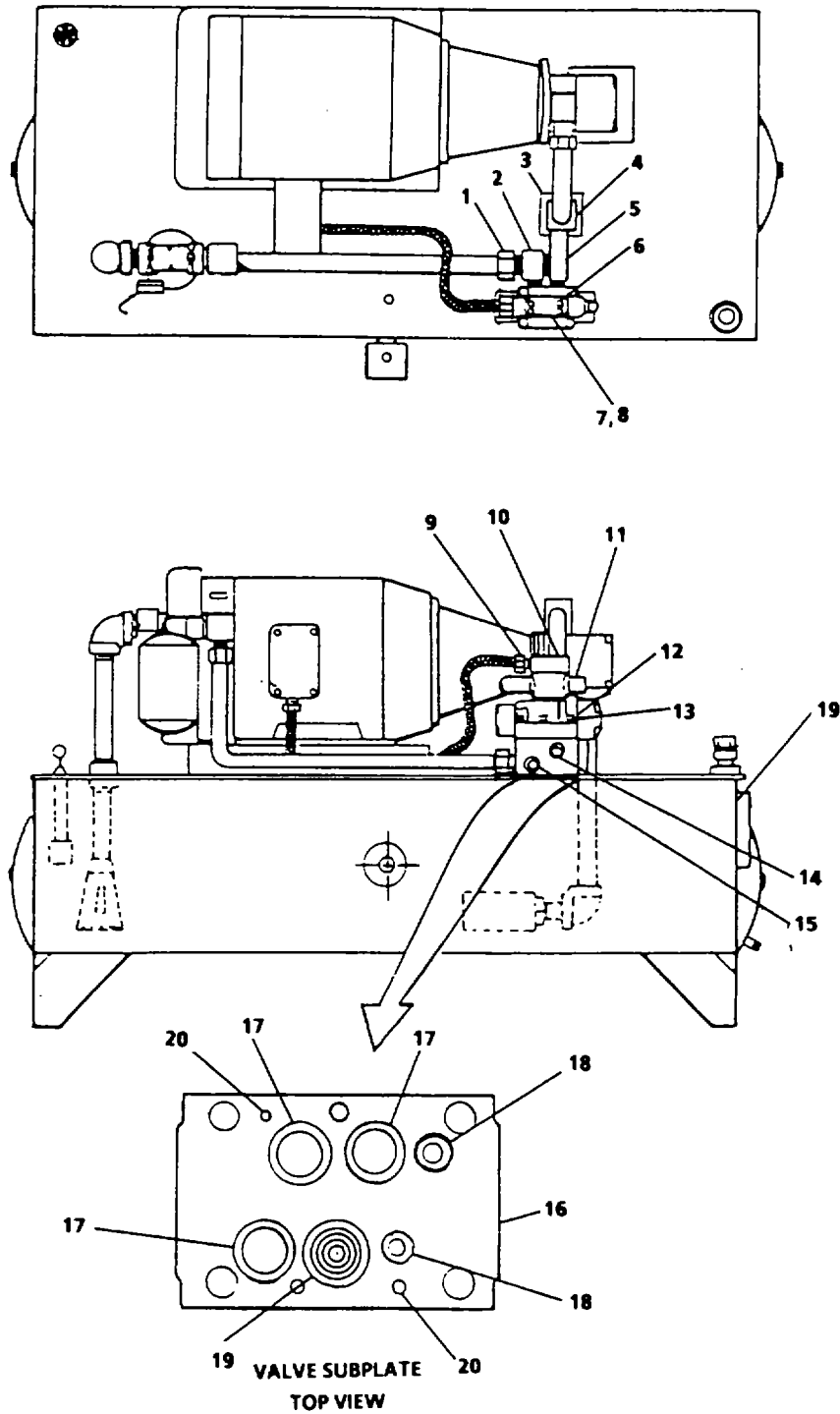

FIGURE 2-9. Directional Control Valve.

- g. Disconnect conduit nut (9) from wiring box (10) and remove conduit assembly and electrical wire connections from wiring box (10).
- h. Remove six mounting screws (13) securing directional control valve (12) to subplate (16).
- i. Separate directional control valve (12) from subplate (16) and remove valve.
- j. Remove preformed packings (17, 18 and 19) and spring pins (20) from subplate (16).
- k. Install protective covering over subplate (16) ports to prevent entry of foreign matter.

REPLACEMENT

- a. Remove protective covering from subplate (16) ports.
- b. Position preformed packings (17, 18 and 19) and spring pins (20) in subplate (16).
- c. Position directional control valve (12) on subplate (16) with preformed packings and spring pins aligned.
- d. Install six mounting screws (13) and secure directional control valve (12) to subplate (16).
- e. Position conduit assembly and electrical wire connections to wiring box (10) opening.
- f. Secure conduit nut (9) to wiring box (10).
- g. From wiring box (10), connect electrical wire connections to electrical solenoid (11). Remove tags.
- h. Position preformed packing (8) and symbol plate (7) on wiring box (10), aligning plate over screw holes.
- i. Install machine screws (6) and secure symbol plate (7) to wiring box (10).

NOTE

Remove any protective caps/plugs from hydraulic lines.

- j. Connect pipe nipple and fitting (5 and 4) to directional control valve (12).
- k. Connect-fitting (2) to directional control valve (12).
- l. Connect couplers (1) and (3) to fittings (2) and (4).
- m. Connect pipe fittings to port A (15) and port B (14) on subplate (16).
- n. Restore power and check for proper operation, TM 55-1905-223-10.

Section VI. PREPARATION FOR STORAGE OR SHIPMENT

2-21. **Preparation for Storage or Shipment.** Administrative storage of equipment issued to and used by Army activities will have preventive maintenance performed in accordance with the Preventive Maintenance Checks and Services (PMCS) charts before storing. When removing the equipment from administrative storage, the PMCS should be performed to assure operational readiness. Perform the following actions to prepare the windlass for storage:

- a. Perform all PMCS procedures, Table 2-1.
- b. Place the chain stoppers (Devil's Claw) in the chain (paragraph 2-13).
- c. Remove electrical power from the hydraulic power pack and tag "Out of Service - Do Not Operate."
- d. Drain hydraulic fluid from the reservoir (paragraph 2-13).
- e. Remove any loads on the wildcats, such as nylon line, and tighten the windlass hand brake (paragraph 2-13).

CHAPTER 3

INTERMEDIATE DIRECT SUPPORT MAINTENANCE INSTRUCTIONS

There are no direct support maintenance procedures authorized by the Maintenance Allocation Chart.

CHAPTER 4

INTERMEDIATE GENERAL SUPPORT MAINTENANCE INSTRUCTIONS

	<u>Page</u>
Section I. Repair Parts, Special Tools; Test, Measurement, and Diagnostic Equipment (TMDE); and Support Equipment	4-1
Section II. Service Upon Receipt	4-1
Section III. Intermediate General Support Preventive Maintenance Checks and Services (PMCS)	4-2
Section IV. Intermediate General Support Troubleshooting	4-2
Section V. Intermediate General Support Maintenance Procedures	4-5
Section VI. Preparation for Storage or Shipment.....	4-50

Section I. REPAIR PARTS, SPECIAL TOOLS; TEST, MEASUREMENT, AND DIAGNOSTIC EQUIPMENT (TMDE); AND SUPPORT EQUIPMENT

4-1. **Common Tools and Equipment.** For authorized common tools and equipment, refer to the Modified Table of Organization and Equipment (MTOE) applicable to your organization.

4-2. **Special Tools, TMDE, and Support Equipment.** Special tools; test, measurement, and diagnostic equipment; and support equipment requirements are listed and illustrated in the Repair Parts and Special Tools List (RPSTL), TM 55-1905-223-24P. These items are also listed in the Maintenance Allocation Chart (MAC), Appendix B of this manual.

4-3. **Repair Parts.** Repair parts are listed and illustrated in the Repair Parts and Special Tools List (RPSTL), TM 55-1905-223-24P.

Section II. SERVICE UPON RECEIPT

4-4. Checking Unpacked Equipment.

- a. Inspect the equipment for damage incurred during shipment. If the equipment has been damaged, report the damage in accordance with the instructions of DA Pam 738-750.
- b. Check the equipment against the packing slip to see if the shipment is complete. Report all discrepancies in accordance with the instructions of DA Pam 738-750.
- c. Check to see whether the equipment has been modified.
- d. Remove protective caps, plugs, inserts, wrappings, and tape when inspection/ inventory is completed. Inspect piping openings for damage. Wipe off dirt, grease, or protective films at time of installation.

e. Remove chocks from resilient mounted components.

4-5. **Initial Setup Procedure.** Includes operational checks and inspections that are not performed for a routine startup. Direct support maintenance personnel will perform initial setup in accordance with the operator's manual, TM 55-1905-223-10.

4-6. **Normal Startup.** Refer to the operator's manual, TM 55-1905-223-10.

4-7. **Shutdown Procedure (Usual or Unusual).** Refer to the operator's manual, TM 55-1905-223-10.

Section III. INTERMEDIATE GENERAL SUPPORT PREVENTIVE MAINTENANCE CHECKS AND SERVICES (PMCS)

4-8. **PMCS.** There is no PMCS at the general support level. See Chapter 2, Section III .

Section IV. INTERMEDIATE GENERAL SUPPORT TROUBLESHOOTING

4-9. **Troubleshooting.** Both a symptom index and a troubleshooting table are provided. The symptom index will help you locate the information you need for troubleshooting.

SYMPTOM INDEX

	Troubleshooting Procedure (Table 4-1)
CHAIN	
Jumps the wildcat	Item 4
CLUTCH	
Fails to lock in or out	Item 3
GEARBOX	
Vibration/Noise	Item 5

SYMPTOM INDEX - CONT

	Troubleshooting Procedure (Table 4-1)
HAUL-BACK AND PAYOUT	
No shaft rotation	Item 1
No wildcat rotation	Item 2
SLOW ROTATION	
	Item 7
WINDLASS	
Fails to hold load in neutral	Item 6

Table 4-1 lists the common fault conditions that may be found during operation or maintenance of the equipment. Look for causes and do corrective actions in the order listed. This manual cannot list every symptom that may show up, and it cannot list all of the possible causes and corrective actions. If a symptom is not listed, or if it keeps up after you have performed the corrective actions, notify your supervisor.

Table 4-1. General Support Maintenance Troubleshooting

Malfunction
Test or Inspection
Corrective Action

1. No shaft-rotation in haul-back or payout.
 - STEP 1. Check for electrical power at the hydraulic power pack.
Repair power distribution system (TM 55-1905-223-24-18).
 - STEP 2. Check for defective hydraulic motor. Hydraulic pressure is applied and automatic brake is releasing.
Repair hydraulic motor (para. 4-13).
 - STEP 3. Check for defective automatic brake. Hydraulic pressure is applied but no audible indication the automatic brake is releasing.
Repair automatic brake (para. 4-12).
 - STEP 4. Check for defective directional control valve. Hydraulic pressure is present at the valve input with no indication of automatic brake release.
Repair directional control valve (para. 4-18).

Table 4-1. General Support Maintenance Troubleshooting - CONT

Malfunction	Test or Inspection	Corrective Action
2. No wildcat rotation with clutch engaged and haul-back/payout switch activated.	STEP 1. Check for defective clutch. Visually observe clutch mechanism. Clutch lugs should be firmly meshed with lugs on the wildcat (FIGURE 4-4).	Replace clutch (para. 4-11).
3. Clutch fails to lock in or out.	STEP 1. Check for defective clutch locking mechanism. Visually inspect where the lock fits over the bearing housing. Locking arm should stay firmly in place. (FIGURE 4-4).	Replace clutch (para. 4-11).
4. Chain jumps the wildcat.	STEP 1. Check for defective wildcat chain sprockets.	Replace wildcat (para. 4-11).
5. Gearbox vibrations/noise.	STEP 1. Check gearbox oil level.	Refill as necessary.
	STEP 2. Check gearbox mounting bolts (para. 4-11).	Tighten bolts.
6. Windlass fails to hold load in neutral.	STEP 1. Check for automatic brake slipping.	Repair automatic brake (para. 4-12).
7. Slow Rotation.	STEP 1. Check oil level at power pack reservoir.	Refill as necessary.
	STEP 2. Check hydraulic pressure at power pack pressure gauge.	Repair pump (para. 4-16).

Section V. INTERMEDIATE GENERAL SUPPORT MAINTENANCE PROCEDURES

MAINTENANCE OF BOW ANCHOR WINDLASS SUBSYSTEM.

4-10. Replace Bow Anchor Windlass Subsystem. (FIGURES 4-1 and 4-2)

This task covers: a. Removal, b. Repair, c. Assembly.

INITIAL SETUP

Tools

Tool kit, general mechanic's,
5180-00-699-5273
Tool kit, machinist's measuring,
580-00-278-9919
Lifting sling, P/N 3375958
Work barge crane
Caliper set micrometer outside
0-6 inches, 5210-00-554-7134

Equipment Condition

Windlass shutdown. Refer to
TM 55-1905-223-10.
Electrical power removed from
hydraulic power pack and tagged
"Out of Service."

Materials/Parts

Fibrous rope P/N MILR17343
Fibrous rope P/N CGS21R5
Gasket P/N D4-0135-0604
Chain stopper P/N 49-9127-0000,
P/N 49-9128-0000
Headless straight pin P/N 65-3776-8070
Towing bridle P/N 43-1334-0000
Bow anchor P/N 49-0830-0000
Detachable link P/N 49-9141-0000,
P/N 49-9141-0100
Swivel P/N 49-9145-0000
Shackle P/N 43-4120-8070
Steel anchor chain P/N 49-9125-0000
Grease, Item 3, Appendix C
Electrical ID tags, Item 7, Appendix C
Sandpaper, Item 8, Appendix C
Solvent, Item 6, Appendix C

OVERVIEW

This procedure includes many difficult tasks with different pieces of heavy equipment. For the bow anchor you will need the help of a work barge. Be very careful when moving anchor and chain.

REMOVAL**WARNING**

The bow anchor is heavy (2000 lbs). Secure the anchor to the double bitt (2) with a rope of sufficient strength to prevent the anchor from falling. A blow from a falling anchor could be fatal.

a. Remove Bow Anchor.

- (1) Attach a work barge crane to the anchor shackle (11).
- (2) Lower anchor until anchor (10), detachable link (13), swivel (12), and shackle (11) are free of the hawse pipe and laying on barge.
- (3) Disconnect anchor from steel anchor chain (14) by removing shackle, swivel, and detachable link.

WARNING

The steel anchor chain is heavy. Maintain positive control of the rate of chain pay out and haul back at all times. Be sure the chain stoppers (Devil's Claw) are in place any time the chain is not in motion. Be sure sufficient manpower is present to lay out the chain properly. A blow from chain or links could result in serious injury.

b. Remove Steel Anchor Chain.

- (1) Secure the anchor end of chain to most forward closed rope chock (2), using a length of rope.
- (2) Remove the chain stoppers (1 and 8).
- (3) Slowly pay out chain from the chain locker, using windlass wildcat to control chain movement.

NOTE

Be sure to have several soldiers to flake out the chain on the deck as it is being paid out.

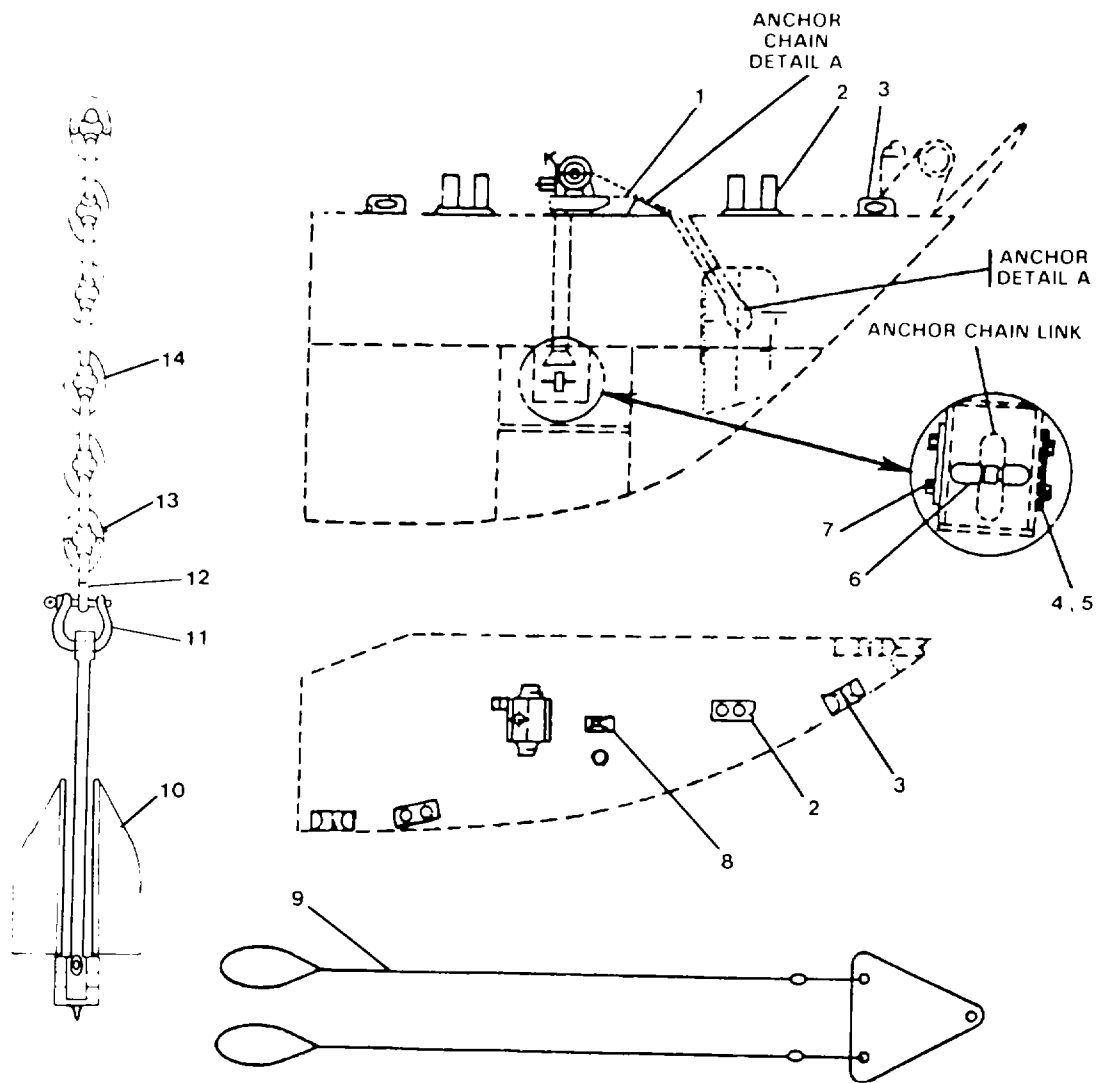

FIGURE 4-1. Bow Anchor Windlass Subsystem.

- (4) Remove chain link secured to chain locker bulkhead as follows:
 - (a) Remove screws (17) securing retaining seal plate (4).
 - (b) Remove plate (4) and gasket (5).
 - (c) Remove straight headless pin (6) from chain link.
- (5) Completely pay out remaining links of chain from chain locker.
- (6) Remove towing bridle (9) from its storage and place with anchor chain for inspection.

REPAIR

a. Repair Ropes.

- (1) Inspect ropes for evidence of fraying, chafing, glazing, or mildew.

NOTE

Limits of acceptable rope damage are found in Marine Crewman's Handbook, FM 55-501.

- (2) Replace any rope not meeting specifications required.

b. Repair Bow Anchor.

- (1) Inspect shackle, swivel, and detachable link for metal friction wear, corrosion, or other physical damage. Replace if metal wear exceeds 5% of total metal, or corrosion is deeper than 5% of thickness of part. Using caliper set micrometer, measure outside diameter of part or chain. If wear is 5% or more of outside diameter, part or chain should be replaced. Replace any damaged parts. Sandpaper, clean with solvent, and paint corroded areas.

NOTE

Be sure the swivel has sufficient grease for proper lubrication.

- (2) Inspect the anchor for corrosion or other physical damage as follows:

NOTE

Be sure the flukes pivot area has sufficient grease for proper lubrication.

- (a) Inspect flukes for point breakage.

(b) Inspect flukes pin and attaching hardware for metal cracks, corrosion, or other physical damage.

(3) Replace anchor if massive cracks are discovered.

c. Repair Steel Anchor Chain. (See FIGURE 4-2.)

(1) Inspect each standard link for pitting from corrosion, cracks, or other physical damage.

(2) Using caliper set micrometer, measure each detachable link pitting for corrosion or cracks. Outside diameter of link should not be less than 5% of 1-1/8 inch (1.069 inch).

(3) Clean minor corrosion from any links not requiring repair. Use sand paper or solvent as required.

(4) If anchor chain is found with corrosion, pitting, or other physical damage exceeding 5%, the entire shot (15-fathom chain length) must be replaced.

(5) To replace a shot containing a weak link, perform the following action

(a) Remove head pellet plug (1).

(b) Drive out tapered pin (2).

(c) Separate coupling plates (3).

(d) Remove C-Link (4) from standard link anchor chain.

(e) Repeat steps (a) through (d) on opposite end of shot.

(f) Remove shot containing weak link.

(6) Inspect straight headless pin for corrosion, wear, or damage. Measure pin with caliper set micrometer. Outside diameter should not be less than 5% of original outside diameter. Clean with sand paper or solvent or replace.

(7) Inspect chain stoppers for wear, cracks, corrosion, or other evidence of physical damage. Clean or replace as required, as in (6) above.

(8) Inspect towing bridle as follows:

(a) Check cables for fraying, broken strands, or corrosion.

(b) Check plate for wear around the attaching holes, corrosion, or other physical damage. Replace as required in (6) above.

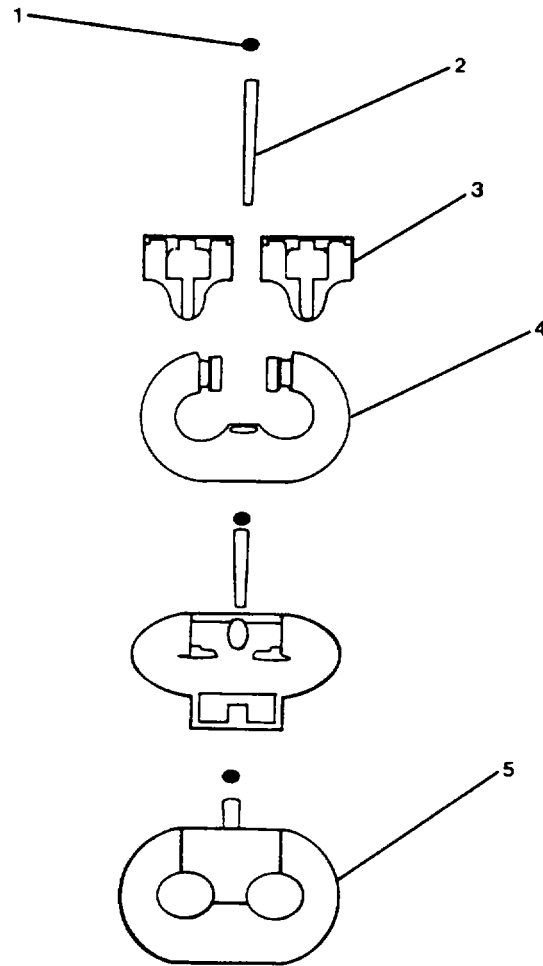

FIGURE 4-2. Detachable Link.

ASSEMBLY

- a. Bridle. Replace towing bridle to its storage area.
- b. Steel Anchor Chain.
 - (1) Pay end of chain into chain locker.
 - (2) Secure end link to bulkhead fitting by inserting straight headless pin (6)-
 - (3) Secure pin by installing gasket (5) and replacing retaining seal plate (4) and screws (7).
 - (4) Using windlass cathead, slowly haul back chain into chain locker until only chain length from cathead to forward closed rope chock (3) remains on deck.
 - (5) Free anchor end of chain from closed rope chock (3).

WARNING

The bow anchor is heavy. Secure the anchor to the double bitt(s) with a rope of sufficient strength to prevent the anchor from falling. Falling anchor may cause death/injury to personnel.

- c. Install Bow Anchor.
 - (1) Feed anchor chain through hawse pipe down to anchor shaft.
 - (2) Connect detachable link, swivel, and shackle to anchor.
 - (3) Using anchor windlass, hawse anchor.
- d. Install Chain Stoppers. Place chain stoppers in position to prevent chain from moving.

4-11. **Replace/Repair Bow Anchor Windlass Assembly.** (FIGURES 4-3 through 4-7)

This task covers: a. Disassembly, b. Repair, c. Assembly.

INITIAL SETUP

Tools

Tool kit, general mechanic's,
5180-00-699-5273
Torque wrench,
5120-01-125-5190
Lifting sling P/N 3375957

Equipment Condition

Electrical power removed from hydraulic
power pack and tagged "Out of Service."
Anchor chain removed (para. 4-10).
Hydraulic lines removed (para. 2-14).

Materials/Parts

Bow anchor windlass P/N MSW-112-TH
Bearing unit housing bushing
P/N MSW-112-TH-007
Gypsy cathead winch P/N MSW-112-TH-002
Brake band lining P/N MSW-112-TH-022
Brake band P/N MSW-112-TH-021
Gasket P/N MSW-112-TH-071
Spline coupling P/N MSW-112-TH-068
Sand paper, Item 8, Appendix C
Machine key P/N MSW-112-TH-050
Electrical ID tags,
Item 7, Appendix C

REMOVAL

WARNING

To prevent injury/death to personnel, two soldiers are required in disassembly of bow anchor windlass, because of weight of the unit.

a. Remove Drive Mechanism.

- (1) Disconnect tubing (5, FIGURE 4-3).
- (2) Attach a lifting sling to support drive mechanism and remove four hex head cap screws (7, FIGURE 4-4), hex nuts (6) and lockwashers (5) securing drive mechanism and remove drive mechanism.
- (3) Remove bolts (8 and 9, FIGURE 4-3).
- (4) Remove coupling housing (1).

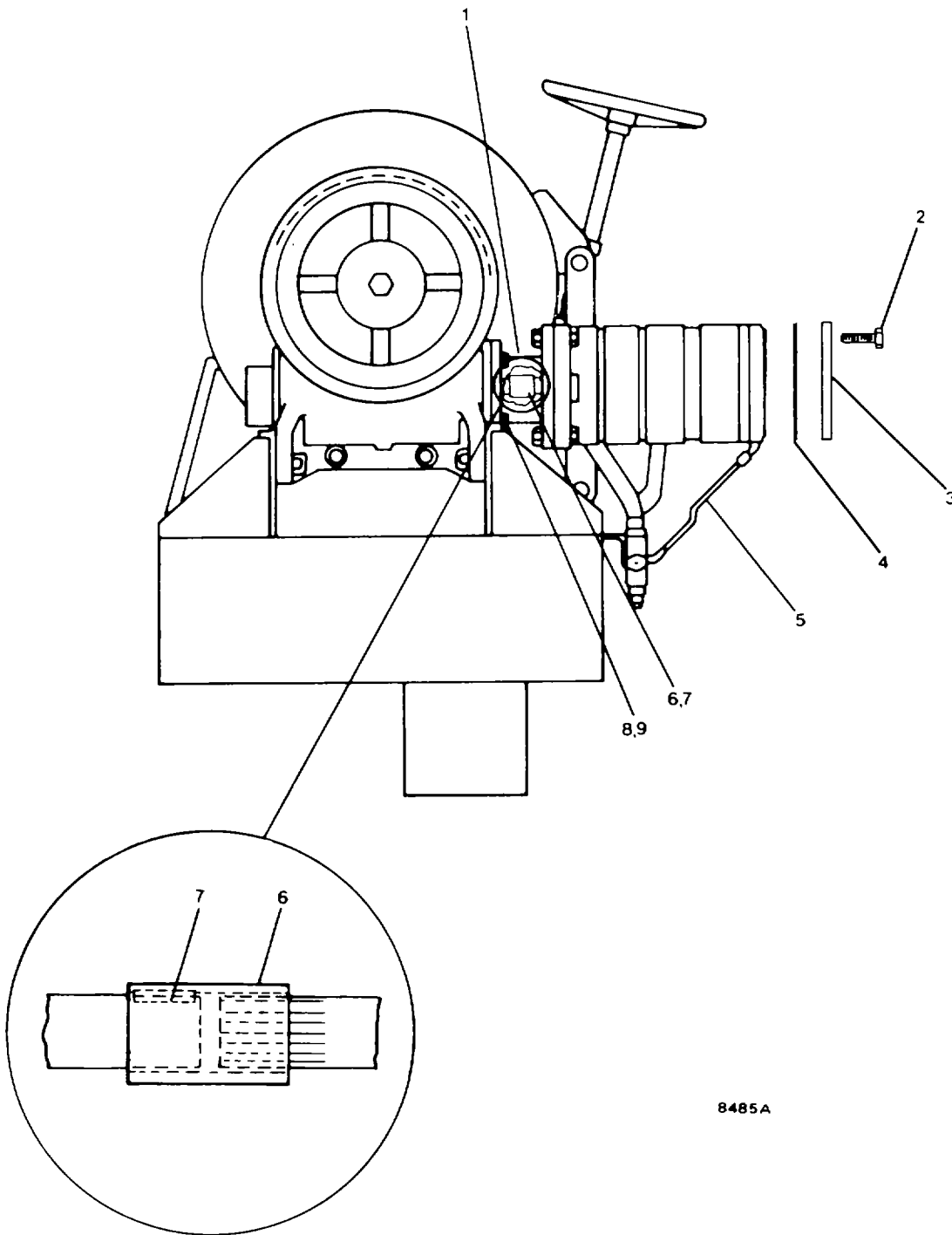

8485A

FIGURE 4-3. Bow Anchor Windlass Drive Components.

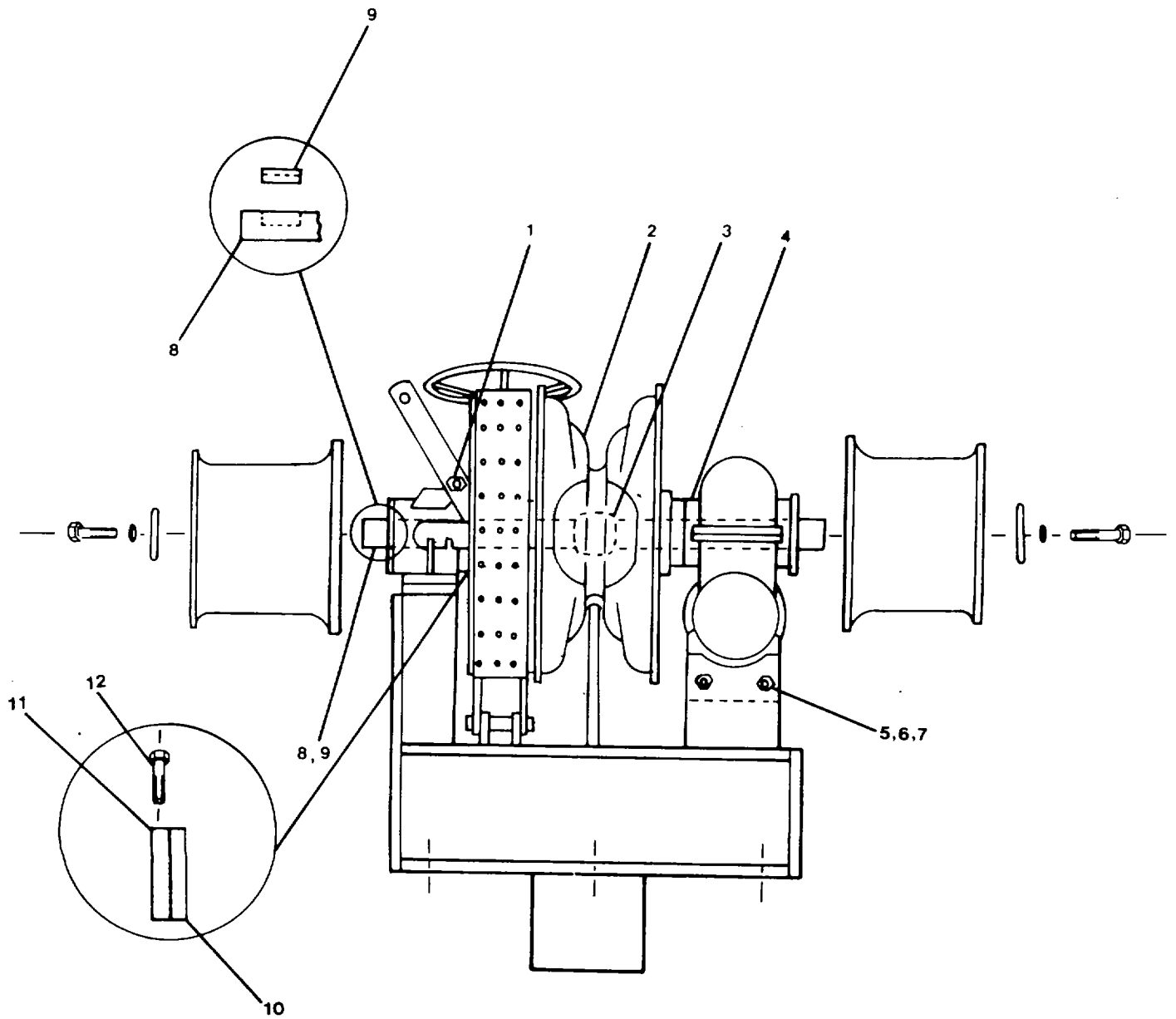

FIGURE 4-4. Bow Anchor Windlass Clutch and Drive Components.

- (5) Remove coupling spline (6).
- (6) Remove key (7) from spline (6).

NOTE

This item is a candidate for direct replacement by vendor.

b. Remove Both Catheads.

- (1) Remove capscrew (1, FIGURE 4-5) and lock washer (2) securing retaining plate (3).
- (2) Remove retaining plate (3).

WARNING

To prevent injury/death to personnel, use a lifting sling to remove catheads, because of the heavy weight.

- (3) Remove cathead (4).
- (4) Remove machine key (5) from shaft.

c. Remove Manual Control Brake.

- (1) Remove self-locking nut (1, FIGURE 4-6) securing manual brake handlewheel (2).
- (2) Remove wheel (2).
- (3) Remove machine key (3).
- (4) Loosen shaft collar (13) setscrew.
- (5) Remove brake rod (4) by unscrewing from anchor brake pin (8), and remove shaft collar (13).
- (6) Remove top and bottom cathead pins (5), lockwashers (6) at both sides and lubrication fittings (7).
- (7) Remove top brake pin (10).
- (8) Remove bottom brake pin (9).
- (9) Remove anchor brake arms (11).
- (10) Remove anchor brake pin (8).
- (11) Remove brake band (14) and lining (15).

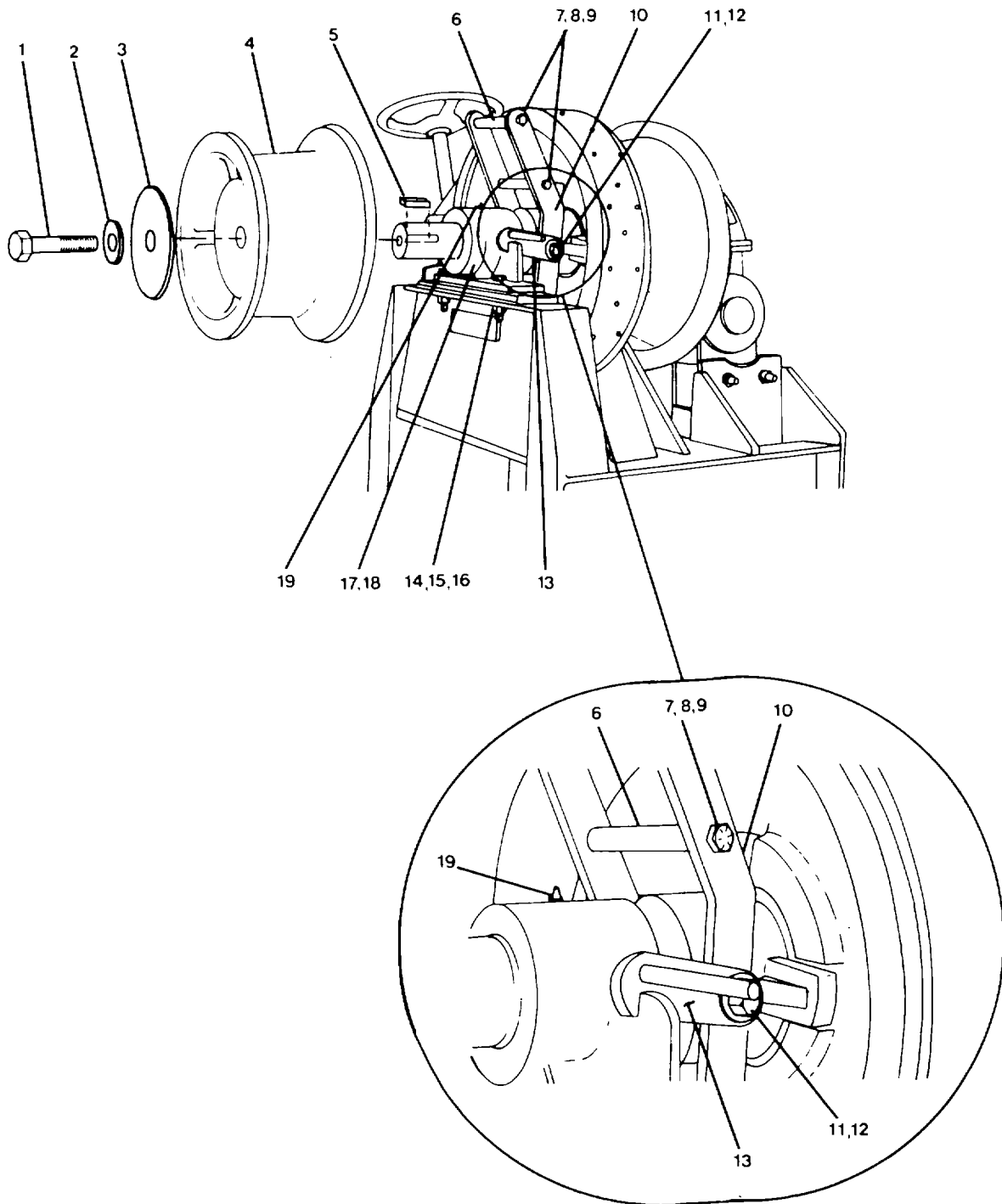

FIGURE 4-5. Bow Anchor Windlass Cathead and Clutch Components.

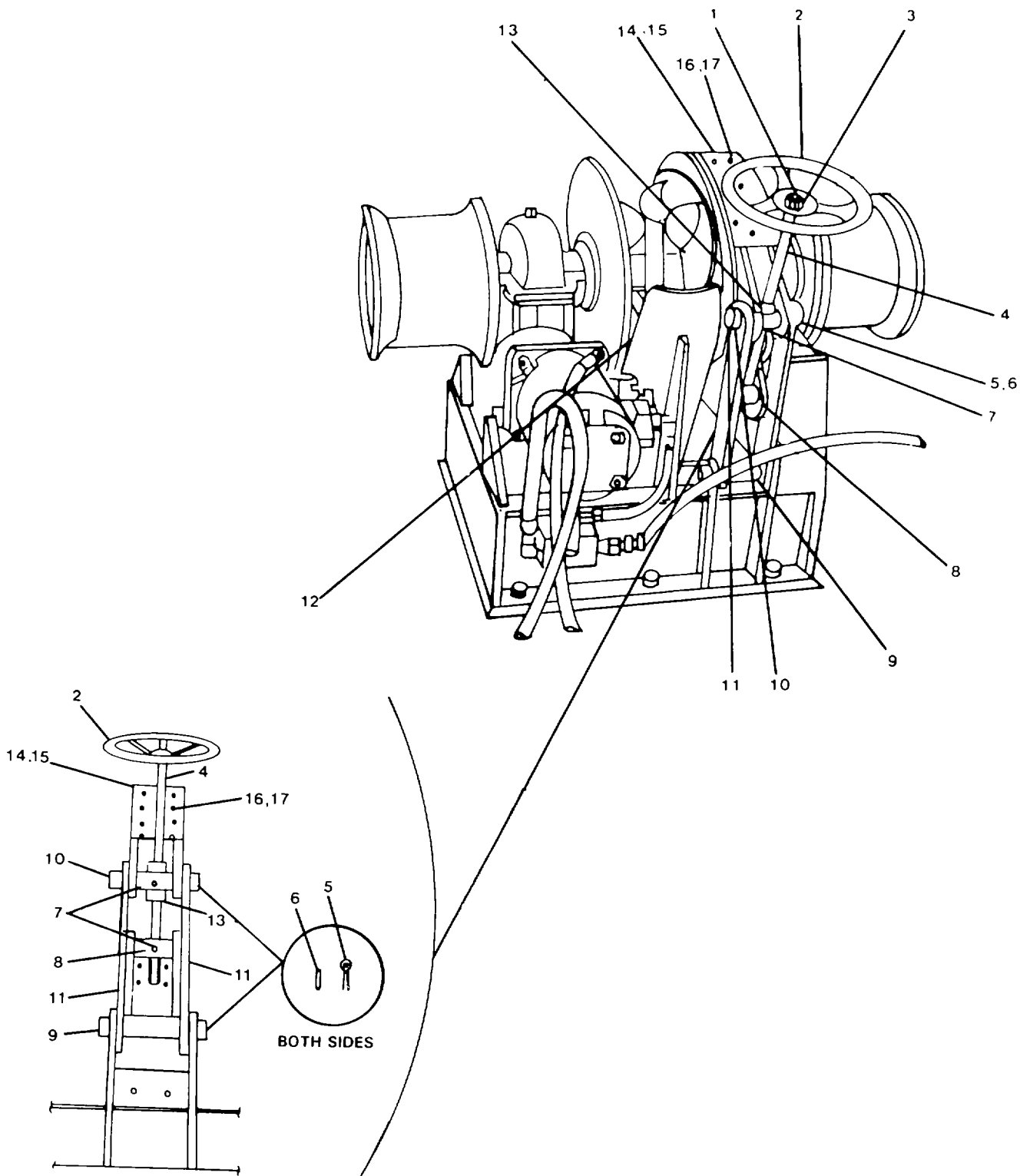

FIGURE 4-6. Bow Anchor Windlass Brake and Drum Components.

- (12) Remove brass screw (16) and self-locking nut (17) and remove brake lining (15) from brake band (14).
- d. Remove base mounting hardware (six nuts and bolts).

WARNING

Bow Anchor Windlass is extremely heavy; to prevent injury/death to personnel, two soldiers are required to assist in handling.

- e. Attach lifting sling and remove bow anchor windlass from foundation and set on deck.
- f. Remove Bearing.
 - (1) Remove screw (14, FIGURE 4-5), nut (15), and lock washer (16) securing bearing unit housing (17).
 - (2) Remove housing (17) and lubrication fitting (19).
 - (3) Press bushing (18) from bearing housing (17).
- g. Remove Clutch.
 - (1) Remove screw (7, FIGURE 4-5), nut (8) and lock washer (9) securing manual clutch handle (6).
 - (2) Remove handle (6).
 - (3) Remove shoulder bolt (11) and lock washer (12).
 - (4) Remove clutch lockout (13).
 - (5) Remove capscrew (12, FIGURE 4-4), retaining pillow block and spacer (11).
 - (6) Remove end spacer (11).
 - (7) Remove spool and spacer (10).
 - (8) Remove sliding jaw clutch handle (1).
 - (9) Remove machine key (9) from shaft (8).
- h. Remove Gearbox.

CAUTION

The gear box is heavy. Ensure that lifting gear is adequate.

- (1) Attach lifting gear to the gear box.
- (2) Remove bolts (21, FIGURE 4-7), nuts and washers (19) attaching gear box to mounting frame (20).
- (3) Slide gear box off the drum shaft and swing clear of the windlass and lower to the deck. This will leave the wildcat sitting on the deck with the shaft running through it.

i. Remove Shaft and Wildcat.

CAUTION

To prevent injury to personnel, use lifting sling to remove wildcat from shaft.

- (1) Remove chain stripper (12, FIGURE 4-6).
- (2) Remove bolt (12, FIGURE 4-4) from spacer (11) and remove spacers (10 and 11).
- (3) Attach lifting sling and slide wildcat (2) from shaft.
- (4) Remove lubrication fitting and drum bushing (3).
- (5) Remove shaft spacer (4).
- (6) Remove shaft from frame.

REPAIR

- a. Repair Hand Brake. Check the brake band lining for breaks, cracks or brittleness. Replace brake band and brake band lining if necessary.
- b. Repair Cathead.
 - (1) Inspect the-cathead surface for nicks, burrs, scratches, or other irregularities that could damage fibrous rope. Sand or otherwise smooth out any rough areas.
 - (2) Check cathead shaft tunnel for evidence of other physical damage. Replace as required.
- c. Repair Bearing.
 - (1) Check bearing unit housing bushing for damage or corrosion.
 - (2) Inspect bushing for a tight fit in housing.
 - (3) Replace bushing if necessary.

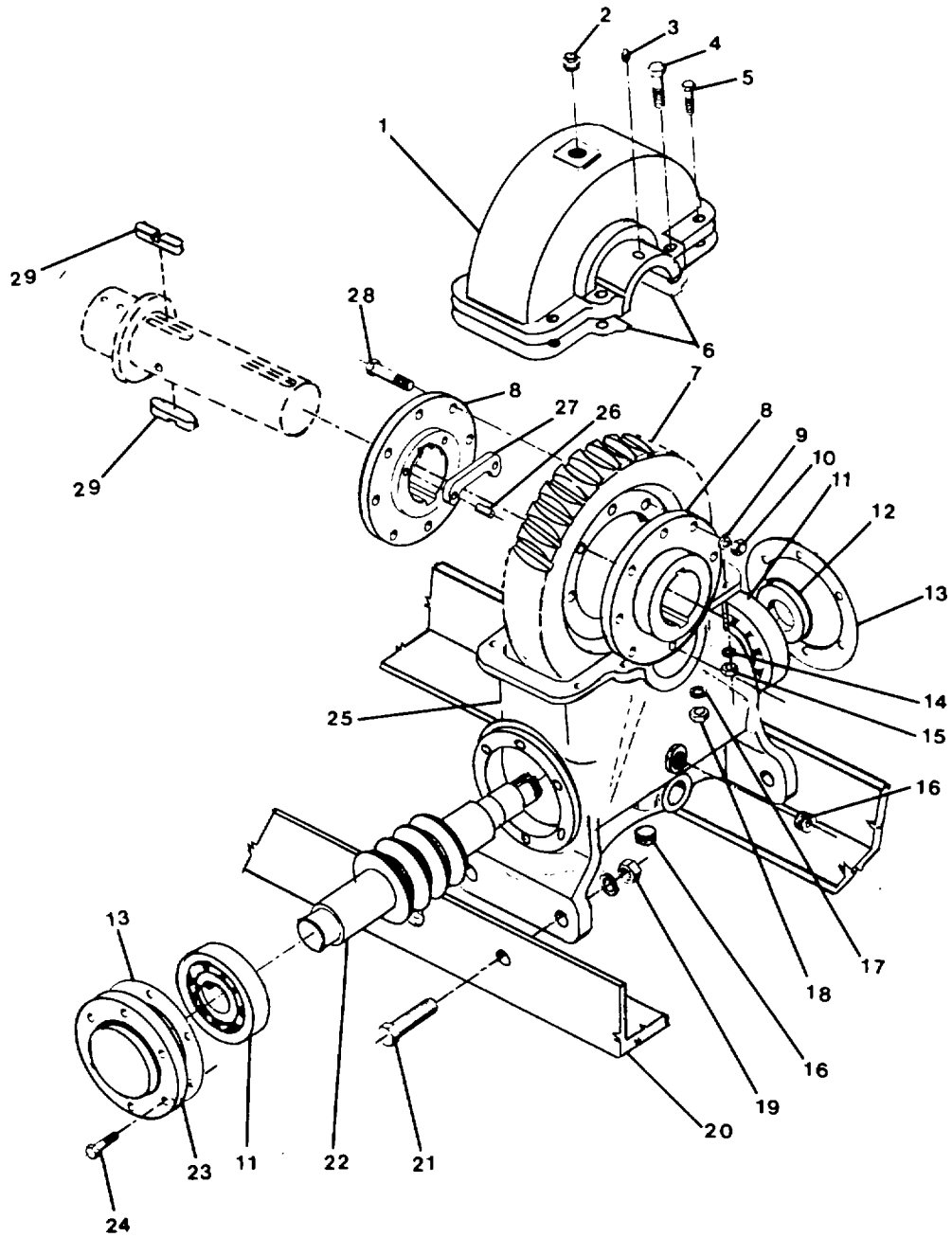

FIGURE 4-7. Gear Box Assembly.

d. Repair Drive Mechanism.

- (1) Check the spline coupling for tooth damage, cracks, chips, or breakage.
- (2) Replace the spline coupling as required.

ASSEMBLY**CAUTION**

To prevent injury to personnel, use lifting to support wildcat.

a. Install Shaft and Wildcat.

- (1) Install shaft in frame (FIGURE 4-4).
- (2) Install shaft spacer (4).
- (3) Install lubrication fitting and drum bushing (3).
- (4) Install lifting sling to wildcat (2) and slide wildcat (2) on to shaft.
- (5) Install spacers (10 and 11) and install bolt (12) in spacer (11) and secure.
- (6) Install chain stripper (12, FIGURE 4-6).

b. Install Gear Box.

- (1) Attach lifting sling to gear box (FIGURE 4-7)
- (2) Lift gear box and slide onto shaft aligning mounting holes.
- (3) Install bolts (21), lock washers (20) and nuts (19) and secure.

c. Install Clutch.

- (1) Install machine key (9, FIGURE 4-4) on shaft (8).
- (2) Install jaw clutch handle (1).
- (3) Install spool and spacer (10).
- (4) Install end spacer (11).
- (5) Install capscrew (12) to retain pillow block and spacer (11).
- (6) Install clutch lockout (13, FIGURE 4-5).
- (7) Install lock washer (12) and shouldered bolt (11).

(8) Install clutch handle (6) and secure with screw (7), lock washer (9), and nut (8).

d. Install Bearing.

(1) Press bushing (18, FIGURE 4-5) into housing.

(2) Install bearing unit housing (17) and lubrication fitting (19).

(3) Secure bearing unit housing (17) with screw (14), lock washer (16), and nut (15).

e. Attach lifting sling to anchor windlass and place windlass on foundation. Replace six nuts and bolts. Tighten bolts to 350 ft-lb (475 N.M) torque.

f. Install Manual Control Brake.

(1) Replace brass screw (16, FIGURE 4-6) and self-locking nut (17) to secure lining (15) to brake band (14).

(2) Install brake band lining (15) and brake band (14).

(3) Replace anchor brake pin (8).

(4) Install top brake pin (10) and bottom brake pin (9).

(5) Install anchor brake arms (11).

(6) Install cotter pins (5), washers (6), and lubrication fittings (7).

(7) Install shaft collar (13) on brake rod (4).

(8) Install brake rod (4) by screwing into anchor brake pin (8). Position shaft collar (13) on brake rod (4) and screw with setscrew.

(9) Install machine key (13).

(10) Install manual control handle (wheel) (2).

(11) Secure wheel (2) with self-locking nut (1).

g. Install Catheads.

(1) Install machine keys (5, FIGURE 4-5) on each end of shaft.

CAUTION

To prevent injury to personnel or damage to equipment, use lifting sling to support catheads.

- (2) Using lifting sling, lift catheads (one at a time) and slide onto shaft.
- (3) Install retaining plates (3).
- (4) Secure retaining plates with lock washers (2) and capscrews (1).

h. Install Drive Mechanism.

- (1) Install key (7, FIGURE 4-4) on spline (6).
- (2) Install coupling spline (6).
- (3) Install coupling housing (1).
- (4) Replace bolts (8 and 9).

CAUTION

To prevent injury to personnel and damage to equipment, use lifting sling to support drive mechanism.

- (5) Attach a lifting sling to drive mechanism and position drive mechanism and install four hex head cap screws (7, FIGURE 4-4) lock washer (5) and hex nuts (6), and secure drive mechanism.
- (6) Connect tubing (5, FIGURE 4-3).

4-12. **Repair Failsafe Brake Assembly.** (FIGURE 4-8)

This task covers: a. Disassembly, b. Repair, c. Assembly.

INITIAL SETUP

Tools

Tool kit, general mechanic's,
5180-00-699-5273
Torque wrench (30-300 foot-pound)
5120-01-125-5190

Equipment Condition

Windlass inoperative (para. 2-13).
Electrical power removed from hydraulic
power pack and tagged "Out of Service.,
(para. 2-13).
Failsafe brake assembly removed
(para. 2-15).

Materials/Parts

Retaining ring P/N 28285
Annular ball bearing P/N 28284
Encased seal P/N 37719
Gasket P/N 35966
Brake disk P/N 36630
Brake disk P/N 36224
Brake disk P/N 36346
Piston P/N 36339
Packing retainer P/N 27967
Preformed packing P/N 27808
Preformed packing P/N 32833
Preformed packing P/N 36701
Safety relief valve P/N 37176
Lubricant, Item 9, Appendix C
Electrical ID Tags, Item 7,
Appendix C
Vise, Item 10, Appendix C

CAUTION

Upon removal of this item, cover, blank, or otherwise protect all openings to prevent foreign material from contaminating the system.

DISASSEMBLY

- a. Remove the screws (19) securing the power plate (23) to the housing (4).
- b. Remove the retaining ring (2) from the power plate (23) end of the assembly.
- c. Remove the ball bearing (3) from the power plate end of the assembly.

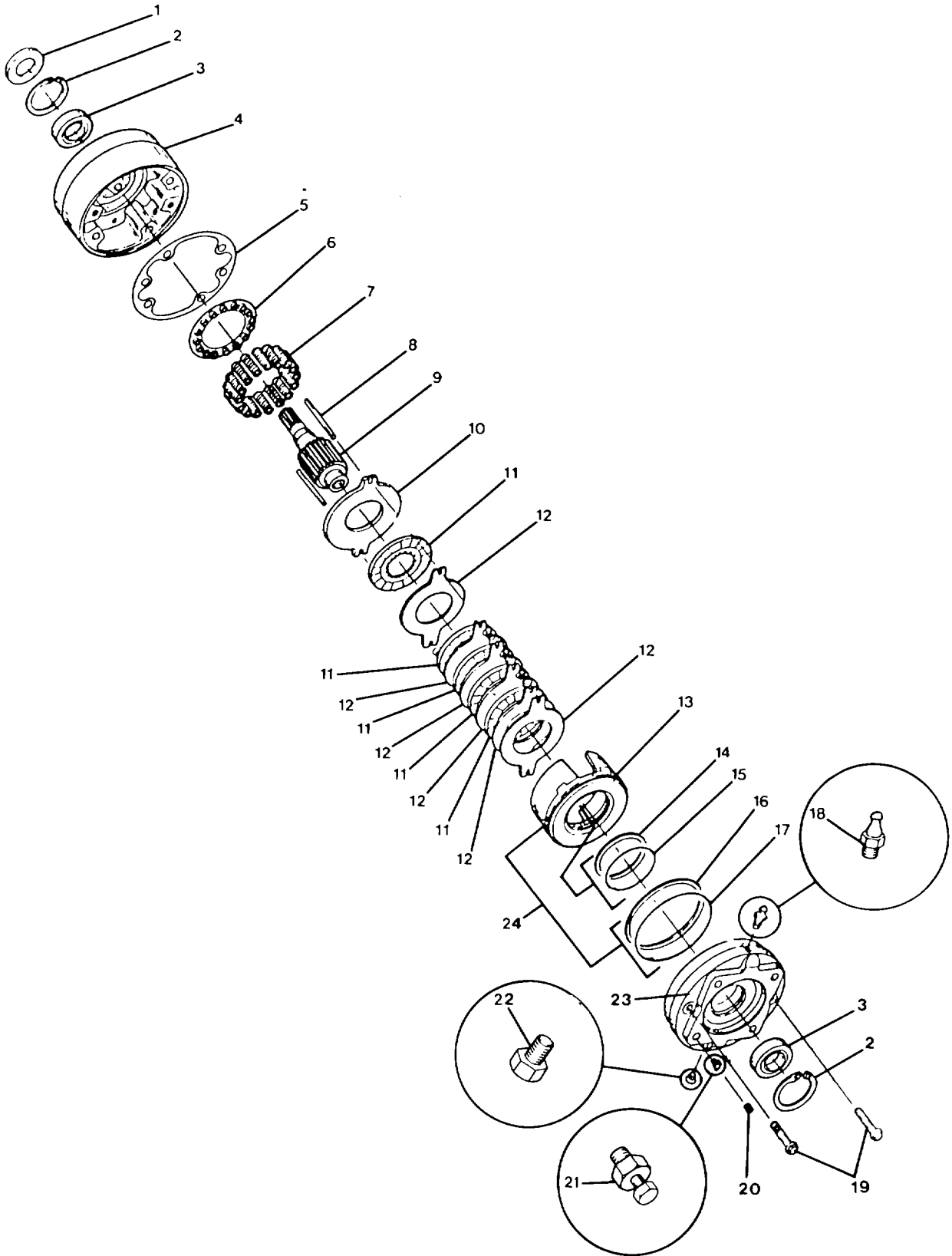

FIGURE 4-8. Failsafe Brake Assembly.

- d. Separate the power plate (23) from the piston (13) and other components as follows:
 - (1) Secure the assembly body in a shop vise.

WARNING

High pressure compressed air apparatus possess potential for serious injury to the eyes and exposed areas of the skin from escaping pressurized air.

Be sure the piston is pointed away from the operator during disassembly and assembly or personal injury could occur.

CAUTION

Do not apply more than 15 psi static air pressure to the brake or damage to the brake could occur.

- (2) Apply 15 psi air pressure to the power plate air fitting (18) to release brake pressure.
 - (3) Pull power plate away from the assembly until the piston is clear. Release air pressure.
- e. Remove the following components from the power plate: Tag for location during assembly.
 - (1) Housing plug (22).
 - (2) Safety relief valve (21).
 - (3) Bleeder valve (18).
- f. Remove the following components from the piston assembly (24):
 - (1) Preformed packings (16 and 17). Discard the packings.
 - (2) Preformed packings (14 and 15). Discard the packings.
 - (3) Primary disc (10).
 - (4) Five friction linings (11).
 - (5) Six stationary discs (12).
 - (6) Piston (13).
- g. Remove the retaining ring (2) on the body end of the assembly.

NOTE

Observe direction of beveled edge of encased seal to ensure correct positioning during replacement.

- h. Remove the encased seal (1). Discard the seal.
- i. Remove the ball bearing (3).
- j. Remove the torque pins (8).
- k. Remove the shaft (9).
- l. Remove the spring (7) and spring retainer (6).
- m. Remove the gasket (5). Discard the gasket.

REPAIR**NOTE**

This item is a candidate for direct replacement.

- a. Inspect the discs (10 and 12) for cracks, warping, or other physical damage. Replace as required.
- b. Inspect the friction lining (11) for discoloration due to excess heat, or other physical damage. Replace as required.
- c. Inspect the piston (13) for scoring, warping, or other physical damage. Replace as required.

WARNING

High pressure compressed air tanks, piping systems, and air operated devices possess potential for serious injury to the eyes and exposed areas of the skin due to escaping air pressure.

- d. Clean all parts thoroughly with low pressure compressed air.
- e. Check the bearings (3) for proper lubrication, lubricate if needed (Item 9, Appendix C).

ASSEMBLY

- a. Install the preformed packings (14, 15, 16, and 17).
- b. Replace the spring (7) and spring retainer (6) on the shaft (9).
- c. Replace the shaft into the housing (4). Replace gasket (5).
- d. Replace the torque pins (8).
- e. Replace the ball bearing (3) on the body end of the shaft.

NOTE

Ensure beveled edge of encased seal is replaced in same direction as noted in DISASSEMBLY.

- f. Install encased seal (1).
- g. Replace the retaining ring (2) on the body end of the shaft.
- h. Replace the following components into the piston assembly (24):
 - (1) Piston (13).
 - (2) Six stationary discs (12).
 - (3) Five friction lining (11).
 - (4) Primary disc (10).
- i. Replace the piston assembly (24) on to the shaft.
- j. Replace the following components on to the power plate:
 - (1) Bleeder valve (18).
 - (2) Safety relief valve (21).
 - (3) Housing plug (22).
- k. Replace the power plate (23) on to the piston as follows:
 - (1) Secure the assembly in a shop vise.

WARNING

Be sure the piston is pointed away from the operator during disassembly and assembly or personal injury could occur.

High pressure compressed air tanks, piping systems, and air operated devices possess potential for serious injury to the eyes and exposed areas of the skin due to escaping air pressure.

CAUTION

Do not apply static air pressure in excess of 15 psi MAXIMUM to the assembly or damage to the assembly could occur.

(2) Apply 15 psi air pressure to the power plate air fitting to release brake pressure.

(3) Join the power plate and the piston. Release air pressure.

- m. Replace the ball bearing (3) on the power plate end of the assembly.
- n. Replace the retaining ring (2) on the power plate end of the assembly.
- o. Replace the screws (19). Torque alternately to 75-85 ft-lb (102-116 N•m).
- p. Replace the failsafe brake assembly on the bow anchor windlass, paragraph 2-15.
- q. Restore the bow anchor windlass to operating condition, paragraph 2-13.
- r. Operate the windlass, check the operation of the failsafe brake assembly.

4-13. Repair Hydraulic Motor Assembly. (FIGURE 4-9)

This task covers: a. Disassembly, b. Repair, c. Assembly.

INITIAL SETUPTools

Tool kit, general mechanic's,
5180-00-699-5273
Tool kit, machinist's measuring,
5180-00-278-9919
Torque wrench, (30-300 foot-pound)
5120-01-125-5190

Equipment Condition

Windlass inoperative (para. 2-13).
Electrical power removed from hydraulic
power pack and tagged "Out of Service."
Failsafe brake assembly removed (para.
2-15).
Hydraulic motor removed (para. 2-16).

Materials/Parts

Roller bearing P/N 0370720
Preformed packing P/Ns 0370112,
0370137, 0370114, 0370817,
0370811, 0370810, 0370610
Retaining ring P/N 0370111
Retaining ring P/N 0370730
Annular ball bearing P/N 0370711
Seal plate P/N 0370136
Cleaning solvent, Item 6, Appendix C
Emory cloth, Item 11, Appendix C

NOTE

This item is a candidate for direct replacement.

CAUTION

Upon removal of this item, cover, blank, or otherwise protect all openings to prevent foreign material from contaminating the system.

DISASSEMBLY

- a. Remove retaining ring (1).
- b. Remove four bolts (24) from rear housing (8).
- c. Remove front housing (26).

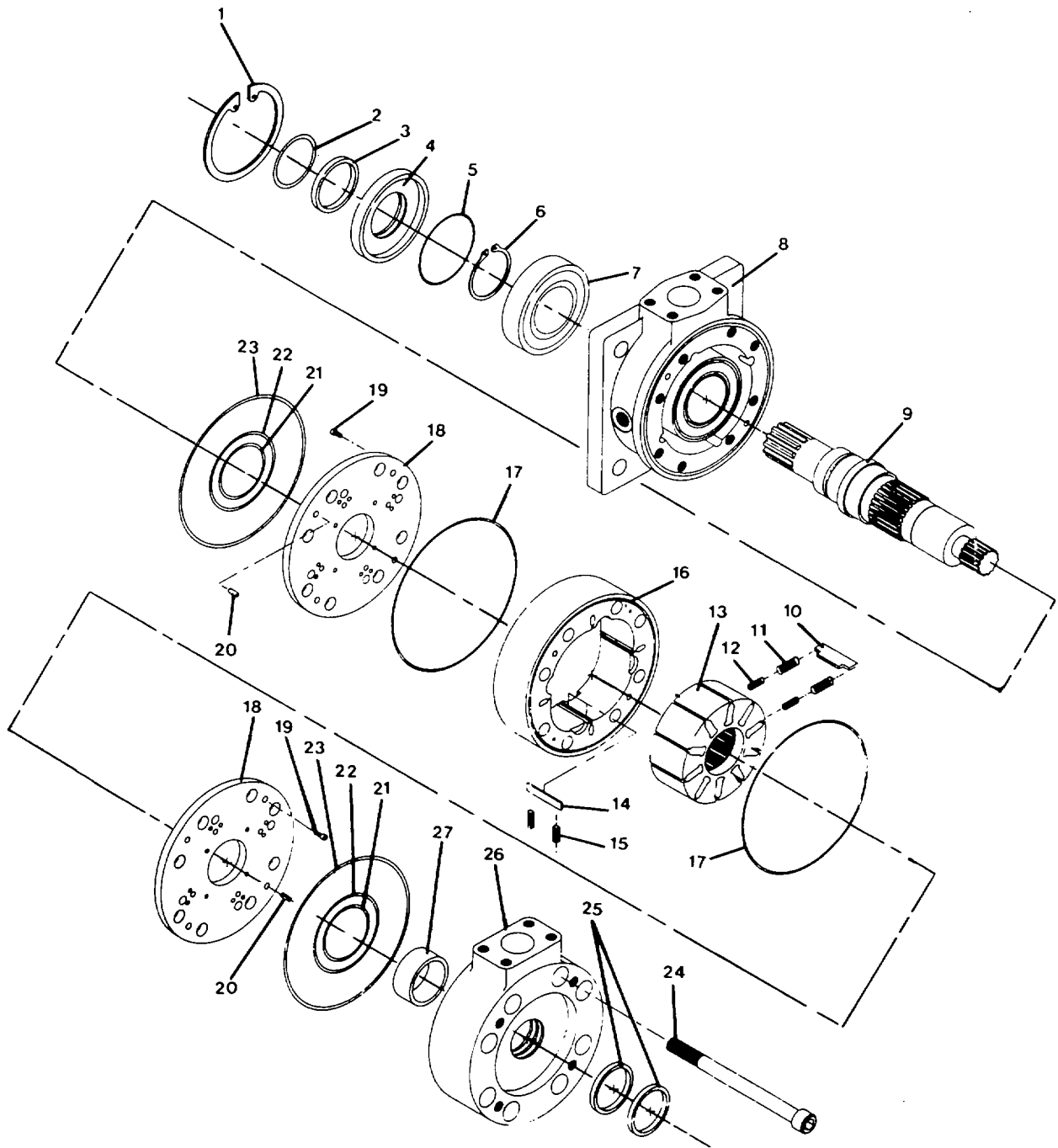

FIGURE 4-9. Hydraulic Motor Assembly.

- d. Remove preformed packings (2 and 3) and discard.
- e. Remove seal plate (4).
- f. Remove preformed packing (5) and discard.
- g. Remove retaining ring (6).
- h. Remove ball bearing (7).
- i. Remove rear housing (8) by sliding off the shaft (9).
- j. Remove preformed packings (25) and discard.
- k. Remove roller bearing (27) from the rear housing (8).
- l. Remove preformed packings (21, 22, and 23) and front and rear housings (8 and 26) and discard.
- m. Remove screws (19) and headless pins (20) securing the plates (18) to the stator (16).
- n. Remove plates (18) from the front and rear of the stator.
- o. Remove front and rear preformed packings (17) and discard.
- p. Remove rotor (13) from the stator.
- q. Remove rotor vane (10).
- r. Remove inner (12) and outer (11) rotor vane springs.
- s. Remove stator vane (14).
- t. Remove stator vane springs (15).

REPAIR

- a. Inspect the seal plate for warping or other physical damage. Replace as required.
- b. Inspect the roller bearing for broken or missing needle rollers, worn faces, or other physical damage. Replace as required.
- c. Using emory cloth, burnish the inside of the stator and the outside of the rotor.
- d. Clean all parts thoroughly with solvent.
- e. Check the ball bearings for scoring, freedom of movement, and smooth operation. Replace as necessary.

ASSEMBLY

- a. Replace stator vane (14) and springs (15).
- b. Replace rotor vane (10) and the inner and outer rotor vane springs (11 and 12).
- c. Replace rotor (13) into the stator (16).
- d. Install new preformed packings (14) into front and rear of stator (16).
- e. Replace plates (18), front and rear of stator, and secure with screws (19) and headless pins (20).
- f. Replace roller bearing (27) into the rear housing (8).
- g. Install preformed packings (21, 22, 23 and 24) into the rear housing.
- h. Replace rear housing onto the shaft (9).
- i. Replace ball bearing (7) onto the shaft.
- j. Replace retaining ring (6).
- k. Install preformed packing (5).
- l. Replace seal plate (4).
- m. Install preformed packings (2 and 3).
- n. Replace preformed packings (21, 22 and 23) into front housing (26).
- o. Replace front housing (26) onto the shaft (9).
- p. Replace four bolts (24). Torque to 115 ft-lbs.
- q. Replace retaining ring (1).
- r. Replace hydraulic motor assembly, paragraph 2-16.
- s. Replace failsafe brake assembly, paragraph 2-15.
- t. Restore bow anchor windlass to operating condition, paragraph 2-13.

CAUTION

Proper fluid must be used for compatibility with the seals, and the viscosity range must meet the recommendations of the manufacturers or damage to the equipment will occur.

- u. Operate the windlass and check the hydraulic motor.

4-14. **Replace/Repair Gear Box Assembly.** (FIGURE 4-10)

This task covers: a. Disassembly, b. Repair, c. Assembly.

INITIAL SETUP

Tools

Tool kit, general mechanic's,
5180-00-699-5273
Tool kit, measuring machinist,
5280-00-278-9919
Torque wrench, (30-300 foot-pound)
5120-01-125-5190
Snap ring pliers, P/N 407

Materials/Parts

Gear box assembly
P/N G34-SLRROX
Gasket P/N 20326
Gasket P/N 20118
Annular ball bearing P/N 20303
Lubrication fitting P/N 21128
Bushing P/N 32839
Gear P/N 21642
Key machine P/N 20574
Retainer, lubricant P/N 20281
Gear box oil, Item 2, Appendix C
Electrical ID tags, Item 7,
Appendix C

Equipment Condition

Windlass inoperative (para. 2-13).
Electrical power removed from hydraulic
power pack and tagged "Out of Service."
Failsafe brake assembly removed
(para. 2-15).
Hydraulic motor removed (para. 2-16).
Cathead removed (para. 4-11).
Gear box assembly removed (para. 4-11).
Chain and anchor removed (para. 4-10).

General Safety Instruction

Check sump pot oil level.

NOTE

This unit is a candidate for direct exchange.

DISASSEMBLY

- a. Remove the screws (5), nuts (15), and lockwashers (14) from the access cover (1).
- b. Remove the screws (4), nuts (18), and lockwashers (17) securing the access cover.
- c. Remove the access cover (1) and gasket (6).
- d. Remove gear (7) by lifting straight up from the housing.

- e. Remove screws (28), nuts (10) and washers (9).
- f. Remove bushings (8) and spacers (27) from gear (7).

NOTE

Spacers are fitted over pins (26).

- g. Remove bolts (24) from cap (23).
- h. Remove cap (23) and gaskets (13). Discard gaskets.
- i. Remove bearings (11) and grease retainer (12) from shaft (22). Discard grease retainer.
- j. Remove shaft (22) from housing (25).
- k. Remove plugs (16) from housing (1).
- l. Remove grease fittings (3) and breather (2) from access cover (1).

REPAIR

CAUTION

During replace/repair of this unit, all openings should be capped/plugged to prevent foreign matter or contamination from entering the system.

- a. Clean all parts with solvent and blow dry.
- b. Inspect bearings (11) for galling, freedom of movement and smooth operation. Replace if necessary.
- c. Inspect bushings (8) for cracks, scoring, sharp edges, and evidence of over heating. Replace if necessary.
- d. Inspect gear (7) for scuffed, nicked, burred, or broken teeth. Replace if necessary .
- e. Inspect machine keys (29). If damage of any kind is found, replace key.
- f. Apply gearbox oil to all metal parts prior to reassembly to ensure adequate lubrication at initial start up.

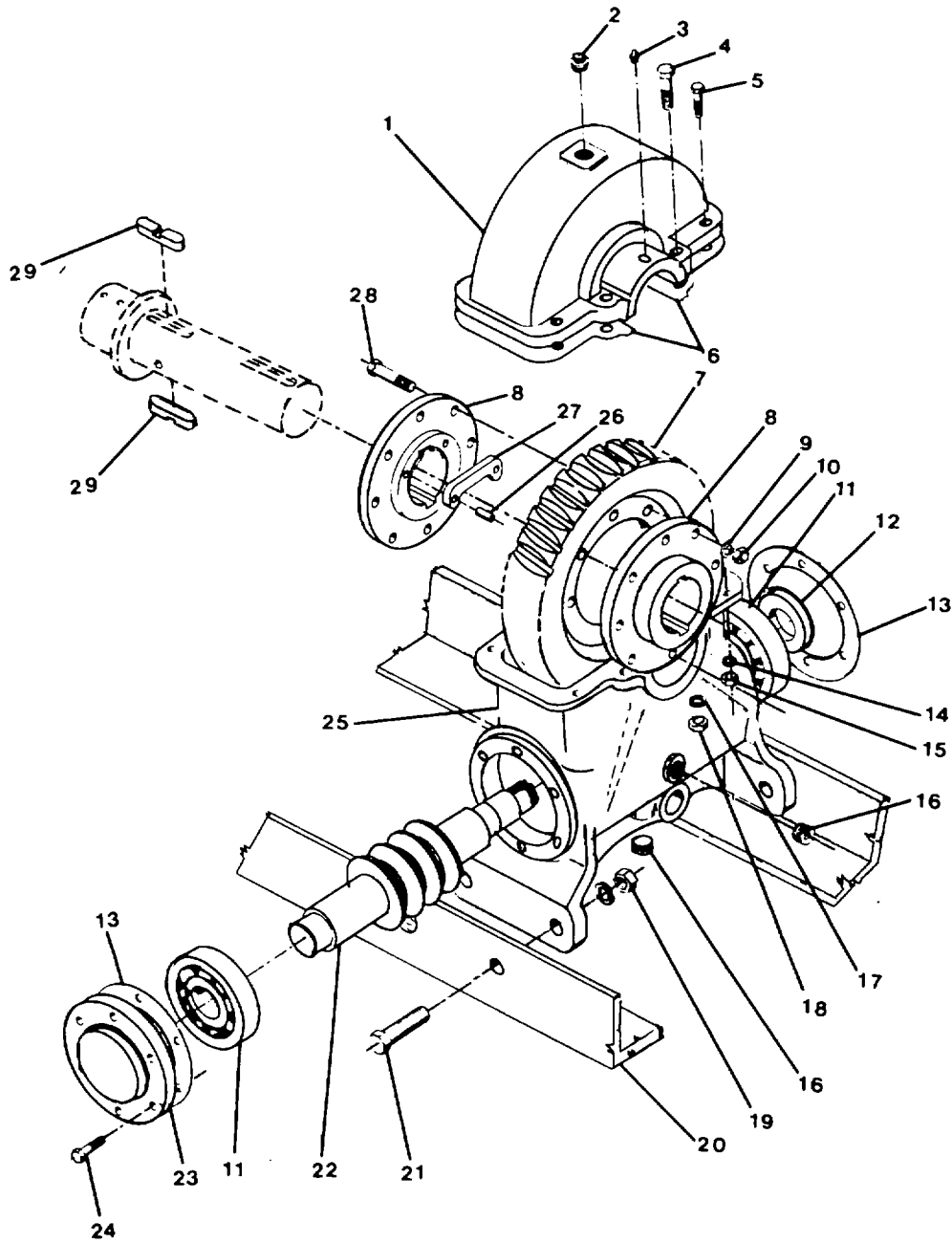

FIGURE 4-10. Gear Box Assembly.

ASSEMBLY

- a. Insert shaft (22) and bearings (11) into housing (25).
- b. Install grease retainer (12) onto shaft (22).
- c. Position gasket (13) and cap (23) to the housing (25) and secure with screws (24).

NOTE

Gasket (13) on the motor side will be installed with the motor.

- d. Install spacers (27) over pins (26) in gear (7),
- e. Position bushings (8) to gear (7) and secure with bolts (28), nuts (10) and washers (9).

NOTE

Ensure that the key ways in bushings line up before securing to the gear.

- f. Set gear (7) into the housing (25).

NOTE

It may be necessary to turn shaft (22) slightly to mesh with gear (7). Bushings (8) will be firmly sealed in the housing when gears are meshed.

- g. Position gaskets (6) to line up with bolt holes in housing (25).
- h. Install access cover (1) to housing (25). Secure with screws (5), nuts (15), and washers (14).
- i. Install screws (4), nuts (18) and washers (17) to complete securing access cover to the housing.

4-15. Repair Hydraulic Power Pack Assembly. (FIGURE 4-11).

This task covers: a. Disassembly, b. Repair, c. Assembly.

INITIAL SETUPTools

Tool kit, general mechanic's,
5180-00-699-5273
Tool kit, measuring machinist,
5280-00-278-9919
Torque wrench,
51200-01-125-5190
Lifting sling P/N 3375958

Equipment Condition

Windlass inoperative (para. 2-13).
Electrical power removed from hydraulic
power pack and tagged "Out of Service."
Reservoir drained (para. 2-13).
Hydraulic power pack assembly removed
from reservoir (para. 2-17).
Inspection cover and gasket removed
(para. 2-17).

Materials/Parts

Reservoir P/N HH-80-3786
Electrical ID tags, Item 7,
Appendix C
Cleaning solvent, Item 6,
Appendix C

NOTE

This item is a candidate for direct exchange with the vendor.

DISASSEMBLY

- a. The only repair authorized at the intermediate general support level is replacement of the reservoir.
- b. Check the interior of the reservoir (1) for oil sludge deposits or other contamination. Clean with solvent as necessary.
- c. Clean all attached parts with cleaning solvent.
- d. Inspect reservoir for damage such as pitting, cracks, or leaks.
- e. Remove reservoir if necessary.
 - (1) Remove nuts and bolts (2, 3) at the base.
 - (2) Using a lifting sling, remove damaged reservoir.

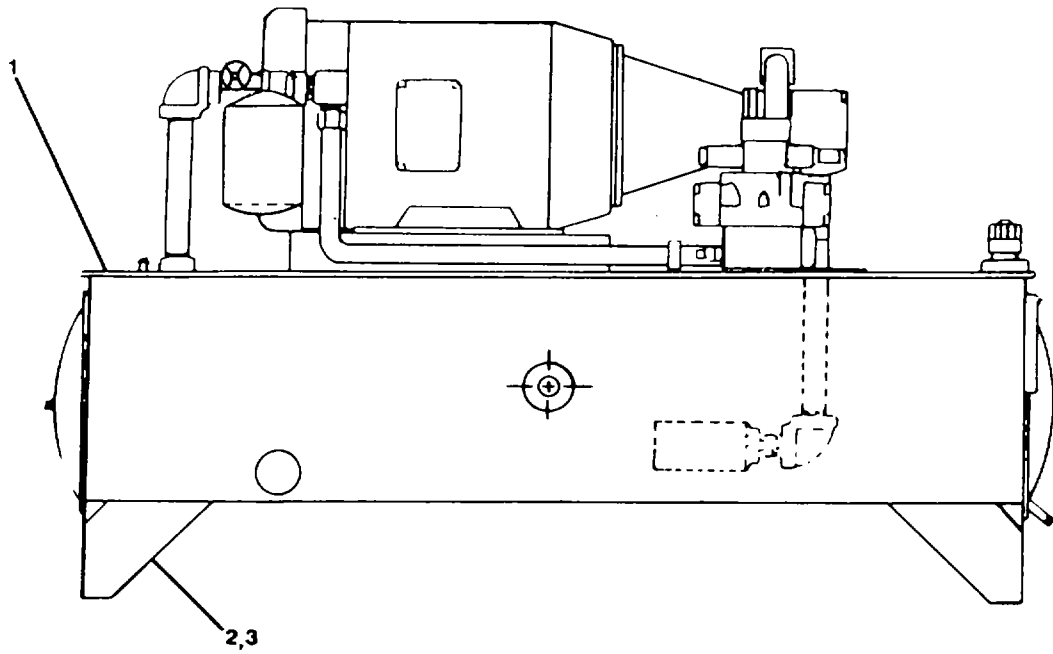

FIGURE 4-11. Hydraulic Power Pack.

REPAIR

This item is a candidate for direct exchange with vendor.

ASSEMBLY

- a. Install new reservoir.
 - (1) Using a lifting sling, place new reservoir in position.
 - (2) Install the bolts and nuts (2, 3) securing the reservoir. Torque to 105 ft-lb.
- b. Replace inspection cover gaskets and inspection cover, paragraph 2-17.
- c. Replace hydraulic power pack assembly onto reservoir, paragraph 2-17.
- d. Fill reservoir, paragraph 2-13.
- e. Connect electrical power, remove tags, and restore windlass to operating condition, paragraph 2-13.

4-16. Repair Hydraulic Pump. (FIGURE 4-12)

This task covers: a. Disassembly, b. Repair, c. Assembly.

INITIAL SETUPTools

Tool kit, general mechanic's,
5180-00-699-5273

Materials/Parts

Preformed packing P/N MS28775-244
Unitized cartridge P/N S24-10724
Electrical ID tags, Item 7,
Appendix C
Cleaning solvent, Item 6, Appendix C

Equipment Condition

Windlass inoperative (para. 2-13).
Electrical power removed from hydraulic
power pack and tagged "Out of Service."
Hydraulic pump removed (para 2-19).

CAUTION

Upon removal of this item, cover, blank, or otherwise protect all openings to prevent foreign material from contaminating the system.

DISASSEMBLY

- a. Remove screws (1) securing the pump housing (2) to the pump mounting cap (6).
- b. Remove pump housing (2) from the pump shaft assembly (5).
- c. Remove unitized cartridge (4) from the shaft assembly.
- d. Remove preformed packing (3) and discard.

REPAIR

- a. Clean all parts thoroughly with solvent.
- b. Inspect unitized cartridge for cracks, scoring, or other physical damage. Replace as required.

ASSEMBLY

- a. Replace preformed packing (3).
- b. Replace unitized cartridge (4).
- c. Install pump housing (2).
- d. Install screws (1).

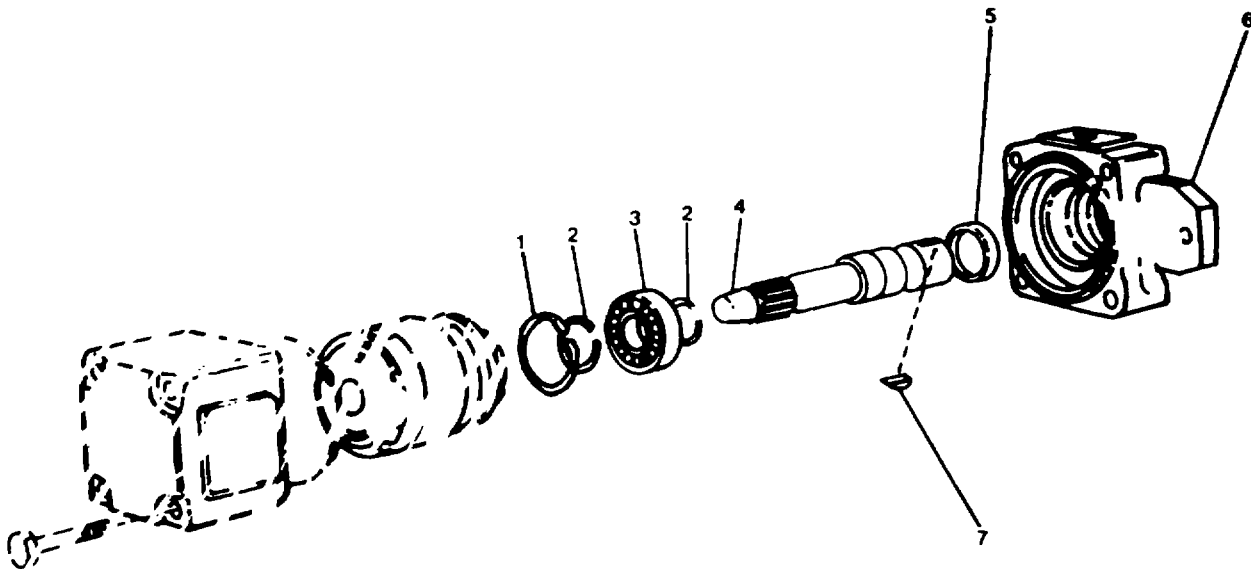

FIGURE 4-12. Hydraulic Pump.

4-17. **Repair Pump Shaft.** (FIGURE 4-13)

This task covers: a. Removal, b. Disassembly, c. Repair, d. Assembly, e. Replacement.

INITIAL SETUP

Tools

Tool kit, general mechanic's,
5180-00-699-5273
Snap ring pliers P/N 407

Materials/Parts

Pump shaft P/N S14-24570
Retaining ring P/N MS 16625-1244
Retaining ring P/N 034-70777 (2)
Annular ball bearing P/N 230-82054
Plain seal P/N 620-82012
Cleaning solvent, Item 6,
Appendix C
Electrical ID tags, Item 7
Appendix C
Bearing lubricant, Item 9,
Appendix C

Equipment Condition

Windlass inoperative (para. 2-13).
Electrical power removed from hydraulic
power pack and tagged "Out of Service."
Hydraulic pump removed (para. 2-19).
Pump housing and unitized cartridge
removed (para. 4-16).

REMOVAL

CAUTION

Upon removal of this item, cover, blank, or otherwise protect all openings to prevent foreign material from contaminating the system.

- a. Remove retaining ring (1) from mounting cap (6).
- b. Remove pump shaft assembly from the front mounting cap (6) by gently tapping the shaft with a lead or plastic tipped hammer.

DISASSEMBLY

- a. Remove woodruff key (7) from shaft (4).
- b. Remove retaining ring (2), front.
- c. Remove ball bearing (3).

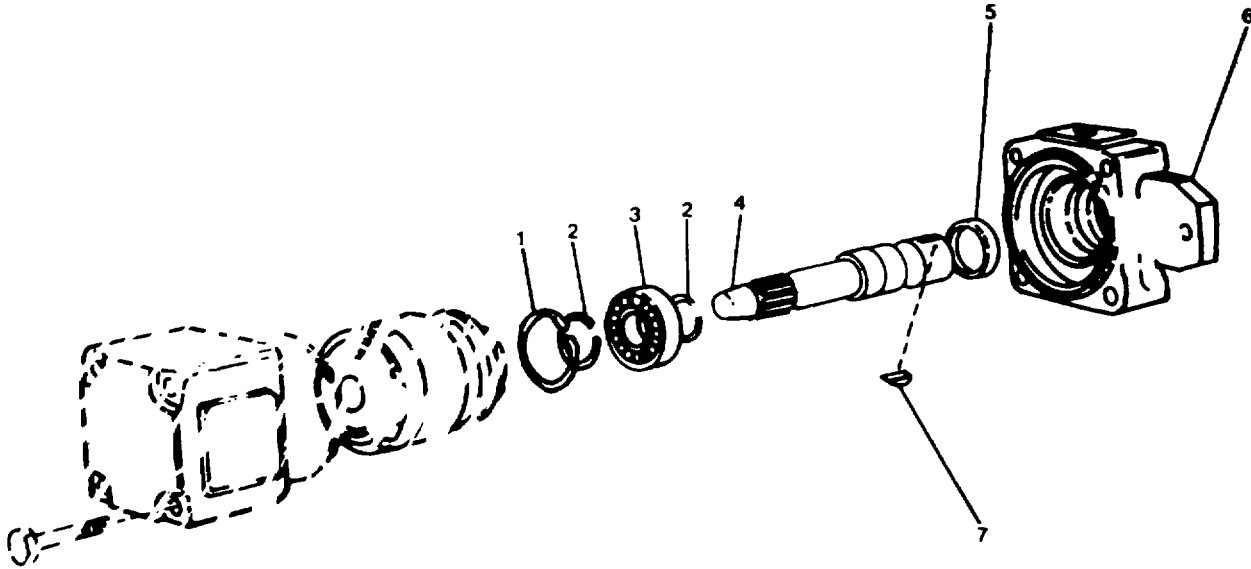

FIGURE 4-13. Pump Shaft.

- d. Remove retaining ring (2), rear.
- e. Remove plain seal (5) from mounting cap (6).

REPAIR

- a. Clean all parts thoroughly with solvent.
- b. Check the bearing (3) for proper lubrication, lubricate as needed, bearing lube, Item 9, Appendix C.
- c. Check all parts for dents, cracks or pitting.
- d. Measure outside diameter of pump shaft (4) with micrometer. Verify pump shaft coupling end is between 0.874 inch and 0.875 inch.
- e. Repair of pump shaft includes replacement of the retaining rings, ball bearing, and plain seal.

ASSEMBLY

- a. Replace woodruff key (7).
- b. Replace plain seal (5) in mounting cap (6).

- c. Replace shaft assembly into the mounting cap (6).
- d. Replace retaining ring (2), rear.
- e. Replace ball bearing (3).
- f. Replace retaining ring (2), front.
- g. Replace retaining ring (1).

REPLACEMENT

Replace hydraulic pump (para. 2-19) and restore bow anchor windlass to operative condition, paragraph 2-13.

4-18. Repair Directional Control Valve. (FIGURE 4-14)

This task covers: a. Disassembly, b. Repair, c. Assembly.

INITIAL SETUPTools

Tool kit, electrician's,
5180-00-391-1087
Tool kit, general mechanic's,
5180-00-699-5273
Torque wrench,
5120-01-125-5190

Equipment Condition

Windlass inoperative (para. 2-13).
Electrical power removed from hydraulic
power pack and tagged "Out of Service."
Directional control valve removed
(para. 2-20).

Materials/Parts

Electrical solenoid
P/N 120-11058
Helical compression spring
P/N 036-39898
Actuating piston liner
P/N 036-81016
Check valve
P/N 516-39246
Preformed packing P/Ns
695-00118, 695-00013,
695-00119, 675-00006,
695-00008, 695-00011,
695-00222, 695-00012
Cleaning solvent, Item 6,
Appendix C
Electrical ID tags, Item 7,
Appendix C

NOTE

This item is a candidate for direct exchange.

CAUTION

Upon removal of this item, cover, blank, or otherwise protect all openings to prevent foreign material from contaminating the system.

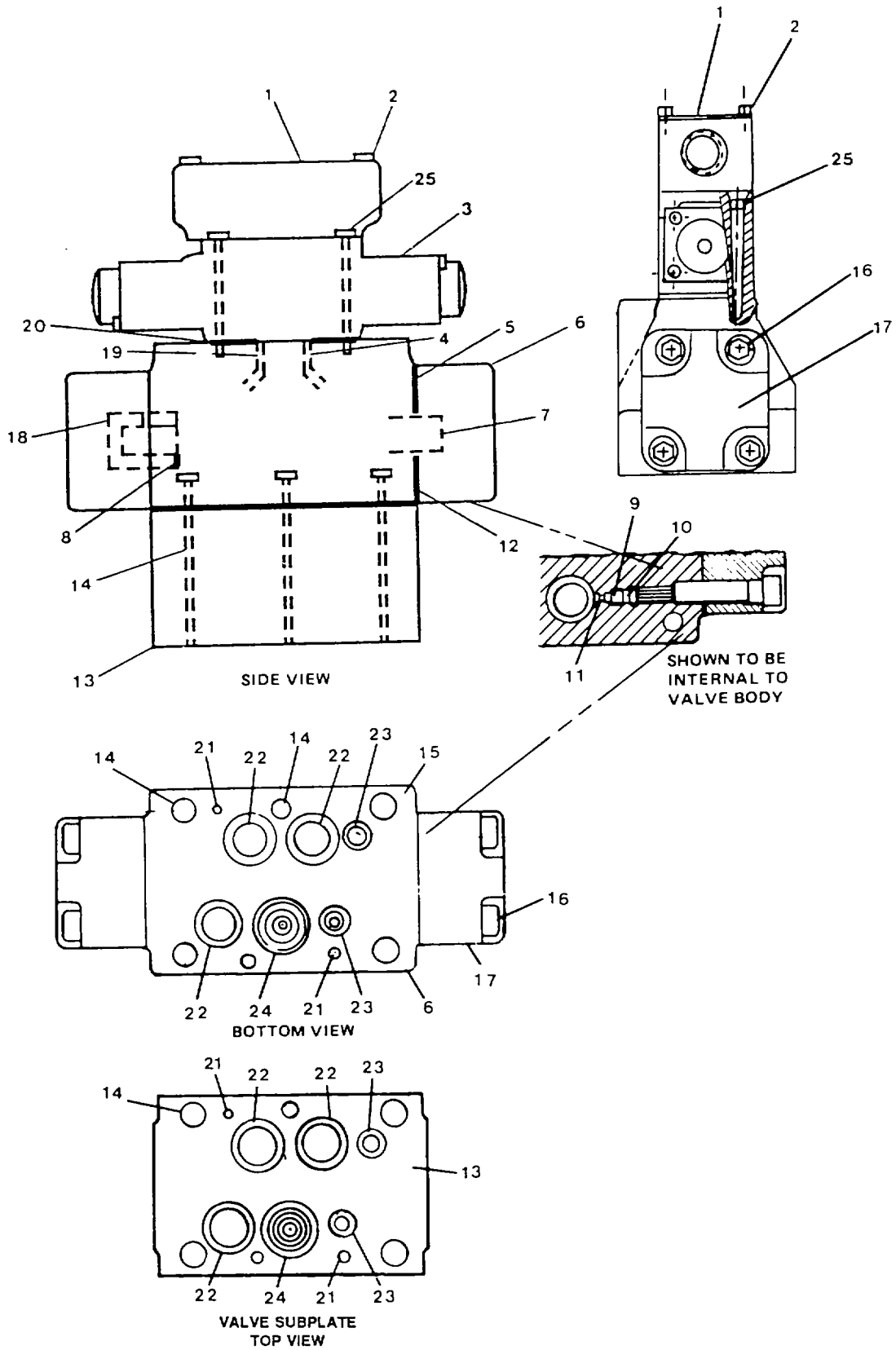

FIGURE 4-14. Directional Control Valve.

DISASSEMBLY

- a. Remove four screws (2) securing the solenoid cover plate (1).
- b. Remove cover plate (1).
- c. Disconnect solenoid electrical connections and tag for identification.
- d. Remove screws (25) and remove solenoid (3) from body (6).
- e. Remove screws (14) securing body (6) to the subplate (13).
- f. Remove body (6) from the subplate (13).
- g. Remove preformed packings (22) and discard.
- h. Remove preformed packings (23) and discard.
- i. Remove preformed packings (24) and discard.
- j. Remove socket head capscrews (16) both sides of valve.

CAUTION

The washers and springs are under spring tension. Use care in removing these parts to prevent loss, or damage to equipment.

- k. Remove end caps (17), both sides of valve.
- l. Remove spring tension washers (8), both sides of valve.
- m. Remove springs (18), both sides of valve.
- n. Remove linear actuating piston (9).
- o. Remove preformed packing (5, 10, 11, 12, 20) and discard.
- p. Remove orifice plug (4).
- q. Remove check valve (19).
- r. Remove spool (7).
- s. Remove roll pin (21).
- t. Remove plain encased seal (15).

REPAIR

- a. Check the body (6) and subplate (13) for oil sludge deposits or other contamination. Clean with solvent as required.

- b. Check all parts for free fluid passage in all parts, openings, and orifices. Clean with solvent as required.
- c. Check all parts for nicks, dents, cracks, scoring, and other physical defects. Replace as required.
- d. Replace all preformed packings.

ASSEMBLY

- a. Replace roll pin (21).
- b. Replace plain encased seal (15) over roll pins (21).
- c. Replace spool (7).
- d. Replace check valve (19).
- e. Replace orifice plug (4).
- f. Install preformed packings (5, 10, 11, 12, 20).
- g. Replace linear actuating piston (9).
- h. Replace springs (18).
- i. Replace spring tension washers (8).
- j. Replace end caps (17).
- k. Replace socket head capscrews (16).
- l. Install preformed packings (22, 23, 24) on body and subplate.
- m. Replace body (18) to subplate (13) and secure with screws (14).
- n. Replace solenoid (3) and secure with screws (25).
- o. Connect electrical leads, using the tags as a guide.
- p. Replace solenoid cover plate (1) and secure with the screws (2).
- q. Restore electrical power to the hydraulic power pack and remove "Out of Service" tag.
- r. Verify operation of the solenoid assembly by operating the windlass in both directions.

Section VI. PREPARATION FOR STORAGE OR SHIPMENT

See Chapter 2, Section VI.

APPENDIX A

REFERENCES

A-1. **Scope.** This paragraph lists the manuals, bulletins, specifications, and miscellaneous publications referenced in this manual or required for maintenance activities.

A-2. Field Manuals.

FM 21-11	First Aid for Soldiers
FM 31-70	Basic Cold Weather Manual
FM 55-501	Marine Crewman's Handbook

A-3. Technical Manuals.

TM 43-0139	Painting Instructions for Field Use
TM 55-1905-223-10	Operator's Manual for Landing Craft, Utility (LCU)
TM 55-1905-223-24-18	LCU 2000 Class Basic Craft Maintenance Manual
TM 55-1905-223-24P-1	Repair Parts and Special Tools List for the LCU 2000 Class Watercraft
TM 750-244-3	Destruction of Army Materiel to Prevent Enemy Use

A-4. Technical Bulletins.

TB 43-0144	Painting of Vessels
TB 55-1900-207-24	Treatment of Cooling Water in Marine Diesel Engines
TB 740-97-4	Preservation of Vessels for Storage

A-5. Military Specifications.

MIL-C-16173C	Rust Preventive, Type P-1
MIL-L-644	Preservative Oil, Type P-9
MIL-L-21260	Preservative Oil, Type P-10

A-6. Miscellaneous Publications.

DA Pam 738-750	The Army Maintenance Management System
LO 55-1905-223-12	Lubrication Order for the LCU 2000 Class Watercraft
*AMC-R 750-11	Use of Lubricants, Fluids, and Associated Products

A-7. Forms.

DA Form 2028 and DA Form 2028-2	Recommended Changes to Publications and Blank Forms
DA Form 2404	Equipment Maintenance and Inspection Worksheet
DA Form 2408-16	Logsheet
DA Form 2410	Logsheet
SF Form 368	Quality Deficiency Report

*Supercedes Darcom-R 750-11

Appendix B. MAINTENANCE ALLOCATION CHART (MAC)

Section I. INTRODUCTION

B-1 THE ARMY MAINTENANCE SYSTEM MAC.

a This introduction (Section I) provides a general explanation of all maintenance and repair functions authorized at various maintenance levels under the standard Army Maintenance System concept.

b The Maintenance Allocation Chart (MAC) in Section II designates overall authority and responsibility for the performance of maintenance functions on the identified end item or component. The application of the maintenance functions to the end item or component will be consistent with the capacities and capabilities of the designated maintenance levels, which are shown in the MAC in column (4) as:

Unit - includes two subcolumns: C (operator/crew) and 0 (unit) maintenance.

Direct Support - includes an F subcolumn.

General Support - includes an H subcolumn.

Depot - includes a D subcolumn.

c Section III lists the tools and test equipment (both special tools and common tools sets) required for each maintenance function as referenced from Section II.

d Section IV contains supplemental instructions and explanatory notes for a particular maintenance function as referenced from Section II.

B-2 MAINTENANCE FUNCTIONS. Maintenance functions will be limited to and defined as follows:

a Inspect. To determine the serviceability of an item by comparing its physical, mechanical, and/or electrical characteristics with established standards through examination (i.e., by sight, sound, or feel).

b Test. To verify serviceability by measuring the mechanical, pneumatic, hydraulic, or electrical characteristics of an item and comparing those characteristics with prescribed standards.

c Service. Operations required periodically to keep an item in proper operating condition, i.e., to clean (includes decontamination, when required), to replace filters, to preserve, to drain, to paint, or to replenish fuel, lubricants, chemical fluids, or gases.

d Adjust. To maintain or regulate, within prescribed limits, by bringing into proper or exact position, or by setting the operating characteristics to specified parameters.

e Align. To adjust specified variable elements of an item to bring about optimum or desired performance.

f Calibrate. To determine and cause corrections to be made or to be adjusted on instruments or test, measuring, and diagnostic equipment used in precision measurement. Consists of comparisons of two instruments, one of which is a certified standard of known accuracy, to detect and adjust any discrepancy in the accuracy of the instrument being compared.

g Remove/Install. To remove and install the same item when required to perform service or other maintenance functions. Install may be the act of emplacing, seating, or fixing into position a spare, repair part, or module (component or assembly) in a manner to allow the proper functioning of an equipment or system.

h Replace. To remove an unserviceable item and install a serviceable counterpart in its place. Replace is authorized by the MAC and is shown as the 3rd position code of the SMR code.

i Repair. The application of maintenance services¹ including fault location/troubleshooting², removal/installation, and disassembly/assembly³ procedures, and maintenance actions⁴ to identify troubles and restore serviceability to an item by correcting specific damage, fault, malfunction, or failure in a part, subassembly, module (component or assembly), and item, or system.

j Overhaul. That maintenance effort (service/action) prescribed to restore an item to a completely serviceable/operational condition as required by maintenance standards in appropriate technical publications (i.e., DMWR). Overhaul is normally the highest degree of maintenance performed by the Army. Overhaul does not normally return an item to like new condition.

k Rebuild. Consists of those service/actions necessary for the restoration of unserviceable equipment to a like new condition in accordance with original manufacturing standards. Rebuild is the highest degree of material maintenance applied to Army equipment. The rebuild operation includes the act of returning to zero those age measurements (hours, miles, etc.) considered in classifying Army equipment and components.

B-3 EXPLANATION OF COLUMNS IN THE MAC, SECTION II

a Column 1 - Group Number. Column 1 lists functional group code numbers, the purpose of which is to identify maintenance significant components, assemblies, subassemblies, and modules with the next higher assembly.

b Column 2 - Component Assembly. Column 2 contains the names of components, assemblies, subassemblies, and modules for which maintenance is authorized.

c Column 3 - Maintenance Function. Column 3 lists the functions to be performed on the item listed in column 2. (For detailed explanation of these functions, see paragraph A-2.)

d Column 4 - Maintenance Category. Column 4 specifies, by the listing of a work time figure in the appropriate subcolumn(s), the category of maintenance authorized to perform the function listed in Column 3. This figure represents the active time required to perform that maintenance function at the indicated category of maintenance. If the number or complexity of the tasks within the listed maintenance function varies at different maintenance categories, appropriate work time figures will be shown for each category. The work time figure represents the average time required to restore an item (assembly, subassembly, component, module, end item, or system) to a serviceable condition under typical field operating conditions. This time includes preparation time (including any necessary disassembly/assembly time), troubleshooting/fault location time, and quality assurance/quality control time in addition to the time required to perform the specific tasks identified for the maintenance functions authorized in the maintenance allocation chart.

The symbol designations for the various maintenance categories are as follows:

- C Operator or Crew
- O Unit Maintenance
- F Direct Support Maintenance (DS)
- H General Support Maintenance (GS)
- D Depot Maintenance

¹ Service - Inspect, test, service, adjust, align, calibrate, and/or replace.

² Fault location/troubleshooting - The process of investigating and detecting the cause of equipment malfunctioning; the act of isolating a fault within a system or unit under test (UUT).

³ Disassembly/assembly - The step by-step breakdown (taking apart) of a spare/functional group coded item to the level of its least component, that is assigned an SMR code for the level of maintenance under consideration (i.e., identification as maintenance significant).

⁴ Actions - Welding, grinding, riveting, straightening, facing, machining, and/or resurfacing.

e Column 5 - Tools and Equipment. Column 5 specifies, by number code, those common tool sets (not individual tools); special tools; Test, Measurement, and Diagnostic Equipment (TMDE); and support equipment required to perform the designated function, which shall be keyed to the tools listed in Section III.

f Column 6 - Remarks. This column shall, when applicable, contain a letter code, in alphabetic order, which shall be keyed to the remarks contained in Section IV.

B-4 EXPLANATION OF COLUMNS IN TOOL AND TEST EQUIPMENT REQUIREMENTS, SECTION III.

a Column 1 - Reference Code. The tool and test equipment reference code correlates with a number code used in the MAC, Section II, Column 5.

b Column 2 - Maintenance Category. The lowest category of maintenance authorized to use the tool or test equipment.

c Column 3 - Nomenclature. Name or identification of the tool or test equipment.

d Column 4 - National Stock Number. The National stock number (NSN) of the tool or test equipment.

e Column 5 - Tool Number. The manufacturer's part number.

B-5 EXPLANATION OF COLUMNS IN REMARKS, SECTION IV.

a Column 1 - Reference Code. The letter code recorded in Column 6, Section II.

b Column 2 - Remarks. This column lists information pertinent to the maintenance function being performed as indicated in the MAC, Section II.

**Section II. MAINTENANCE ALLOCATION CHART
FOR
BOW ANCHOR WINDLASS SUBSYSTEM**

(1) GROUP NUMBER	(2) COMPONENT/ ASSEMBLY	(3) MAINTENANCE FUNCTION	(4) MAINTENANCE LEVEL					(5) TOOLS AND EQUIPMENT	(6) REMARKS
			UNIT		DS	GS	DEPOT		
			C	O	F	H	D		
15	BOW ANCHOR WIND- LASS SUBSYSTEM	INSPECT	2.3					1	A, B
		SERVICE	2.5					1	
		REPLACE				10.5		1,3,5,6	
		REPAIR OVERHAUL	1.5	1.5		19.5		1,3,5,6 *	
1501	BOW ANCHOR WIND- LASS ASSEMBLY	INSPECT	1.3					1	B
		SERVICE	1.5					1	
		REPLACE REPAIR	0.8	1.5		6.0 12.0		1,4,5 1,4,5	
150101	VALVE, HYDRAULIC	REPLACE	0.8					1	C, J, O C, J, O
		REPAIR		1.5				1	
150102	FAILSAFE BRAKE ASSEMBLY	INSPECT	0.5					1	C, E, J, M C, E, J, M
		REPLACE		1.0				1,4	
		REPAIR				2.0		1,4	
150103	HYDRAULIC MOTOR ASSEMBLY	INSPECT	0.5					1	C, D, J C, D, J
		REPLACE		2.0				1,3,4	
		REPAIR				3.5			
150104	GEAR BOX ASSEMBLY	INSPECT	0.5					1	B C, L C, K, L
		SERVICE	0.5					1,3	
		REPLACE				10.0		1,3,4,7	
		REPAIR				20.0			
1502	HYDRAULIC POWER PACK ASSEMBLY	INSPECT	1.0					1	D, F, H, I J, P C
		SERVICE	1.0					1	
		REPLACE		2.0				1,5	
		REPAIR	1.5	2.5		7.5		1,3,4,5	
150201	MOTOR, ALTERNATING CURRENT	INSPECT	0.5					1	I I, N
		SERVICE	0.5					1	
		REPLACE	1.5					1,5	

**Section II. MAINTENANCE ALLOCATION CHART
FOR
BOW ANCHOR WINDLASS SUBSYSTEM (Cont.)**

(1) GROUP NUMBER	(2) COMPONENT/ ASSEMBLY	(3) MAINTENANCE FUNCTION	(4) MAINTENANCE LEVEL					(5) TOOLS AND EQUIPMENT	(6) REMARKS
			UNIT		DS	GS	DEPOT		
			C	O	F	H	D		
150202	PUMP, HYDRAULIC	INSPECT	0.5					1	C, D, J
		SERVICE	1.0					1	
		REPLACE REPAIR	2.5			2.0		1	
15020201	SHAFT, PUMP	REPLACE				3.0		1,7	C, J
		REPAIR				5.0		1,7	
150203	VALVE, CONTROL, DIRECTIONAL	INSPECT	0.5					1	C, J
		REPLACE REPAIR	0.5			1.0		1,2,4	

**Section III. TOOLS AND TEST EQUIPMENT REQUIREMENTS
FOR
BOW ANCHOR WINDLASS SUBSYSTEM**

TOOL OR TEST EQUIPMENT REF CODE	MAINTENANCE CATEGORY	NOMENCLATURE	NATIONAL/NATO STOCK NUMBER	TOOL NUMBER
1	C, O, H	Tool Kit, General Mechanic's	5180-00-699-5273	(50980) SC-5180-90-CL-NO5
2	C, H	Tool Kit, Electrician's	5180-00-391-1087	(80064) 9000S6202-73125ALT2
3	C, H	Tool Set, Measuring, Machinist's	5280-00-278-9919	(50980) SC-5280-95-CL-A01-HR
4	C, O, H	Torque Wrench (30 - 300 inch - pounds)	5120-01-125-5190	
5	C, O, H	Lifting Sling	3940-01-183-9412	(15434)3375958
6	H	Caliper Set, Micrometer, Outside, 0 - 6 inches	5120-00-554-7134	
7	H	Retaining Ring Pliers	5120-00-595-9551	

**Section IV. REMARKS
FOR
BOW ANCHOR WINDLASS SUBSYSTEM**

REFERENCE CODE	REMARKS
A	WEEKLY: GREASE ALL FITTINGS ON THE FAIR LEAD ROLLERS AND ASSOCIATED GUIDE SLEEVES, IN ACCORDANCE WITH MAINTENANCE MANUAL.
B	WEEKLY: GREASE FITTINGS INSTALLED IN THE CLUTCH SCREW, GYPSY WILDCAT, BRAKE SCREW, BEARINGS AND CLUTCH ASSEMBLY, AND GEAR REDUCER.
C	THIS ITEM IS A CANDIDATE FOR DIRECT EXCHANGE WITH THE VENDOR
D	PROPER FLUID MUST BE USED FOR COMPATIBILITY TO SEALS AND OF VISCOSITY RANGE RECOMMENDED BY THE COMPONENT MANUFACTURERS.
E	REMOVE PISTON FROM POWER PLATE BY INTRODUCING LOW PRESSURE AIR (15 PSI) INTO THE HYDRAULIC INLET MAKE SURE PISTON IS DIRECTED AWAY FROM OPERATOR.
F	CHECK THE RESERVOIR OIL LEVEL AND ADD OIL AS REQUIRED. THE LEVEL MUST BE MAINTAINED BETWEEN THE HIGH AND LOW MARKS ON THE SIGHT GAGE.
G	CHECK THE OIL PRESSURE AND OPERATING TEMPERATURE. OIL PRESSURE AT 2900 PSI IS CONSIDERED MAXIMUM. TEMPERATURE AT 150 DEGREES F IS CONSIDERED MAXIMUM.
H	AT LEAST ONCE EVERY SIX MONTHS, OR 2,000 HOURS OF OPERATION, THE RESERVOIR, PUMP SUCTION FILTER, AND AIR VENT FILTER SHOULD BE CLEANED. AT THIS TIME, CHECK THE ENTIRE SYSTEM FOR POSSIBLE FUTURE DIFFICULTIES.
I	AT 2,000 HOURS OR AT 6 MONTHS MAINTENANCE LEVEL, CHECK THE MOTOR/PUMP COUPLING FOR MISALIGNMENT A FLEXIBLE COUPLING IS USED AND SHAFTS MUST BE ACCURATELY ALIGNED PARALLEL AND ANGULARLY. CHECK SETSCREWS IN COUPLINGS FOR LOOSENING. TIGHTEN AS REQUIRED.
J	DURING REPLACE/REPAIR OF HYDRAULIC SYSTEMS, ALL OPENINGS SHOULD BE CAPPED/PLUGGED TO PREVENT FOREIGN MATTER OR CONTAMINATION FROM ENTERING THE SYSTEM.
K	PERIODICALLY, CHECK OIL LEVEL IN SUMP OF GEAR REDUCER. OIL LEVEL TO BE MAINTAINED TO LEVEL OF PLUGS ON SIDE OF UNIT.
L	MAJOR REPAIR/REPLACEMENT OF GEAR REDUCER WILL REQUIRE REMOVAL OF WINCH AND GEAR REDUCER.
M	PLUGS (1 EA ON THE POWER PLATE) AND THE HOUSING ARE TO BE REMOVED FOR FAILSAFE BRAKE INSTALLATION, TAGGED, IDENTIFIED AND REINSTALLED PRIOR TO REMOVAL OF THE FAILSAFE BRAKE.
N	REPAIR OF THIS UNIT IS BY REPLACEMENT

**Section IV. REMARKS
FOR
BOW ANCHOR WINDLASS SUBSYSTEM (Cont.)**

REFERENCE CODE	REMARKS
O	REPAIR OF THE HYDRAULIC VALVE IS BY REPLACEMENT OF THE CARTRIDGE.
P	REMOVE/REPLACE THE ENTIRE HYDRAULIC POWER PAK ASSEMBLY AT THE GENERAL SUPPORT LEVEL.
Q	DEPOT LEVEL REPAIR I MAINTENANCE WILL BE PERFORMED ON A CASE BY CASE BASIS SUBJECT TO APPROVAL AND FUNDING BY THE NATIONAL MAINTENANCE POINT (NMP).

**SECTION IV REMARKS
BOW ANCHOR WINDLASS SUBSYSTEM**

REFERENCE CODE	REMARKS
N	REPAIR OF THIS UNIT IS BY REPLACEMENT.
O	REPAIR OF THE HYDRAULIC VALVE IS BY REPLACEMENT OF THE CARTRIDGE.
P	REMOVE/REPLACE THE ENTIRE HYDRAULIC POWER PAK ASSEMBLY AT THE GENERAL SUPPORT LEVEL.

APPENDIX C

EXPENDABLE/DURABLE SUPPLIES AND MATERIALS LIST

SECTION I. INTRODUCTION

C-1. **Scope.** This appendix lists expendable supplies and materials needed to operate and maintain the LCU 2000 Class Watercraft. These items are authorized by CTA 50-970, Expendable/Durable Items (except Medical, Class V, Repair Parts and Heraldic Items), or CTA 8-100, Army Medical Department Expendable Items.

C-2. **Explanation of Columns.**

a. Column (1) - Item Number. This number is assigned to the entry in the listing and is referenced in the narrative instructions to identify the material (for example, "Use cleaning compound, Item 5, App. C").

b. Column (2) - Level. This column identifies the lowest level of maintenance that requires the listed item.

As applicable:

C - Operator/Crew

O - Organizational Maintenance

F - Direct Support Maintenance

H - General Support Maintenance

c. Column (3) - National Stock Number. This is the National stock number assigned to the item; use it to request or requisition the item.

d. Column (4) - Description. Indicates the Federal item name and, if required, a description to identify the item. The last line for each item indicates the Federal Supply Code for Manufacturers (FSCM) in parentheses followed by the part number.

e. Column (5) - Unit of Measure (U/M). Indicates the measure used in performing the actual maintenance function. This measure is expressed by a two character alphabetical abbreviation (for example, ea, in, pr). If the unit of measure differs from the unit of issue, requisition the lowest unit of issue that will satisfy your requirements.

SECTION II. EXPENDABLE/DURABLE SUPPLIES AND MATERIALS LIST

(1) ITEM NO	(2) LEVEL	(3) NATIONAL STOCK NUMBER	(4) DESCRIPTION	(5) U/M
1	O		Wiping rag	
2	O, H		Gear box oil	
3	O, H		Grease	
4	O		Drain pan	
5	H		Cap plug	
6	H		Cleaning solvent	
7	H		Electrical ID tags	
8	O, H		Sandpaper	
9	H		Bearing lubricant	
10	H		Vise	
11	H		Emory Cloth	
12	O, H		Meg-ohm-meter	
13	O		30-gallon container	

APPENDIX D

TORQUE VALUES

D-1. **Scope.** SAE capscrews are graded according to the strength of the capscrew. They are marked on the head so the correct strength and torque value are known. The tables in this appendix will list the capscrew markings with correct torque values as well as values for pipe plugs and metric bolts.

CAUTION

When replacing capscrews, always use a capscrew of the same measurement and strength as the capscrew being replaced. Using incorrect capscrews can result in equipment damage. Bolts threaded into aluminum require much less torque.

NOTE

Always use torque values listed in the tables when specific torque values are unknown. The torque values listed in the tables are based on the use of lubricated threads.

Table D-1. Capscrew Markings and Torque Values

Capacity Body Size		SAE Grade #5 Cast Iron or Steel			SAE Grade #6 or #7 Cast Iron or Steel			SAE Grade #8 Cast Iron or Steel		
Inches-Thread		Torque		Torque		Torque		Torque		
	ft-lb	kgm	N•m	ft-lb	kgm	N•m	ft-lb	kgm	Nom	
1/4	-20	8	1.1064	10.8465	10	1.3630	13.5582	12	1.6596	16.2698
	-28	10	1.3830	13.5582				14	1.9362	18.9815
5/16	-18	17	2.3511	23.0489	19	2.6277	25.7605	24	3.3192	32.5396
	-24	19	2.6277	25.7605				27	3.7341	36.6071
3/8	-16	31	4.2873	42.0304	34	4.7022	46.0978	44	6.0852	59.6560
	-24	35	4.8405	47.4536				49	6.7767	66.4351
7/16	-14	49	6.7767	66.4351	55	7.6065	74.5700	70	9.6810	94.9073
	-20	55	7.6065	74.5700				78	10.7874	105.7538
1/2	-13	75	10.3725	101.6863	85	11.7555	115.2445	105	14.5215	142.3609
	-20	85	11.7555	115.2445				120	16.5860	162.6960
9/16	-12	110	15.2130	149.1380	120	16.5960	162.6960	155	21.4365	210.1490
	-18	120	16.5960	162.6960				170	23.5110	230.4860
5/8	-11	150	20.7450	203.3700	167	23.0961	226.4186	210	29.0430	284.7180
	-18	170	23.5110	230.4860				240	33.1920	325.3920
3/4	-10	270	37.3410	366.0660	280	38.7240	379.6240	375	51.8625	508.4250
	-16	295	40.7985	399.9610				420	58.0860	568.4360
7/8	-9	395	54.6285	535.5410	440	60.8520	596.5520	605	83.6715	820.2590
	-14	435	60.1605	589.7730				675	93.3525	915.1650
1.0	-8	590	81.5970	799.9220	660	91.2780	894.8280	910	125.8530	1233.7780
	-14	660	91.2780	849.8280				990	136.9170	1342.2420

Table D-1. Capscrew Markings and Torque Values - CONT

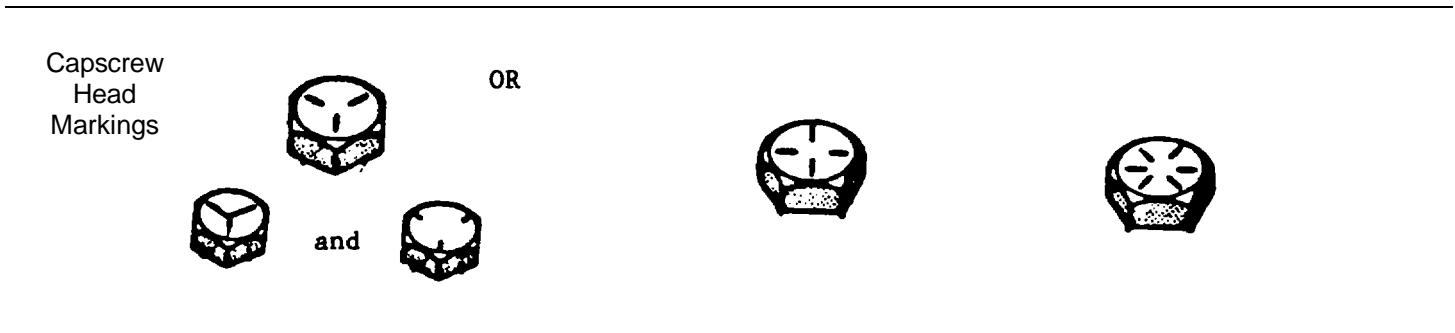

Table D-2. Pipe Plug Torque Values

Thread	Size		In Aluminum Components		In Cast Iron or Steel Components	
	Actual	Thread O.D.	Torque		Torque	
in	mm	(in)	N-m	(ft-lb)	N-m	(ft-lb)
1/16	8.1	(0.32)	5	(45 in-lb)	15	(10)
1/8	10.4	(0.41)	15	(10)	20	(15)
1/4	13.7	(0.54)	20	(15)	25	(20)
3/8	17.3	(0.68)	25	(20)	35	(25)
1/2	21.6	(0.85)	35	(25)	55	(40)
3/4	26.7	(1.05)	45	(35)	75	(55)
1	33.5	(1.32)	60	(45)	95	(70)
1-1/4	42.2	(1.66)	75	(55)	115	(85)
1-1/2	48.3	(1.90)	85	(65)	135	(100)

Table D-3. Metric Bolt Torque Values

Thread for General purposes (size x pitch (mm))	Cast Iron or Steel			
	Head Mark 4 Torque		Head Mark 7 Torque	
	ft-lb	(N•m)	ft-lb	(N•m)
6 x 1.0	2.2 to 2.9	(3.0 to 3.9)	3.6 to 5.8	(4.9 to 7.8)
8 x 1.25	5.8 to 8.7	(7.9 to 12)	9.4 to 14	(13 to 19)
10 x 1.25	12 to 17	(16 to 23)	20 to 29	(27 to 39)
12 x 1.25	21 to 32	(29 to 43)	35 to 53	(47 to 72)
14 x 1.5	35 to 52	(48 to 70)	57 to 85	(77 to 110)
16 x 1.5	51 to 77	(67 to 100)	90 to 120	(130 to 160)
18 x 1.5	74 to 110	(100 to 150)	130 to 170	(180 to 230)
20 x 1.5	110 to 140	(150 to 190)	190 to 240	(160 to 320)
22 x 1.5	150 to 190	(200 to 260)	250 to 320	(340 to 430)
24 x 1.5	190 to 240	(260 to 320)	310 to 410	(420 to 550)

GLOSSARY**Section I. ABBREVIATIONS**

ft-lb	-	Foot-Pound
Nom	-	Newton meter
psi	-	Pounds per square inch

Section II. DEFINITION OF UNUSUAL TERMS

Cathead	-	A drum on the winch shaft to handle rope.
Devil's Claw	-	Common name for a type of chain stopper.
Fake	-	Single turn of rope stowed or coiled down.
Fluke	-	The arm of the anchor that bites into the ground.
Free Wheel	-	To move with no control or opposition.
Glazing	-	Visible evidence of stretch or burn on nylon rope.
Gypsy Head	-	Common name for cathead or drum.
Haul Back	-	To pull a rope or chain inboard.
Hawse Pipe	-	Opening in the bow for the anchor chain to travel.
Pay Out	-	Controlled rate of chain or rope outward travel.
Shot	-	One 15 ft length of chain.
Wildcat	-	The sprocket wheel of a windlass for chain control.
Windlass	-	Machine for working cables and mooring ropes.

ALPHABETICAL INDEX

Subject, Paragraph

Subject, Paragraph

A

Adjustment, Preliminary; 2-6
 Administrative Storage; 1-5, 2-21
 Alternating Current Motor
 Removal; 2-18
 Replace; 2-18

Bow Anchor Windlass Assembly
 Assembly; 4-11
 Disassembly; 4-11
 Repair; 4-11
 Replace; 4-11
 Bow Anchor Windlass Subsystem
 Assembly; 4-10
 Remove; 4-10
 Repair; 4-10
 Replace; 4-10

Characteristics
 Capabilities and Features; 1-6
 Checking Unpacked Equipment; 2-4, 4-4
 Common tools and Equipment; 2-1, 4-1

D

Deprocessing Equipment; 2-5
 Description of Components; 1-7
 Destruction of Army Material; 1-3
 Directional Control Valve
 Assembly; 4-18
 Disassembly; 4-8
 Remove; 2-20
 Repair; 4-18
 Replace; 2-20

E

Equipment Condition; 2-13
 Equipment Data; 1-8

F

Failsafe Brake Assembly
 Assembly; 4-12
 Disassembly; 4-12
 Repair; 4-12
 Replace; 2-15

G

Gearbox
 Repair; 4-14
 Assembly; 4-14
 Disassembly; 4-12

H

Hydraulic Motor Assembly
 Assembly; 4-13
 Disassembly; 4-13
 Removal; 2-16
 Repair; 4-13
 Replace; 2-16
 Hydraulic Power Pack Assembly
 Assembly; 4-16
 Disassembly; 4-16
 Remove; 2-19
 Repair; 4-16
 Replace; 2-19
 Hydraulic Valve
 Remove; 2-14
 Repair; 2-14
 Replace; 2-14

L

Location and Description of Major Components; 1-7

M

Maintenance Forms and Records and Reports; 1-2
 Maintenance Procedures
 Unit; 2-12
 General Support; 4-10

P

PMCS; 2-10, 4-8
 Preparation for Storage or Equipment;
 1-5, 2-21
 Principles of Operation; 1-10

ALPHABETICAL INDEX

Subject, Paragraph

Subject, Paragraph

P

Pump Shaft

Repair; 4-17

Assembly; 4-17

Disassembly; 4-17

Replace; 4-17

Remove; 4-17

R

Repair Parts; 2-3, 4-3

Reporting Equipment Improvement

Recommendations; 1-4

S

Safety, Care, and Handling; 1-9

Scope; 1-1

Servicing and Adjustment, Preliminary;

2-16

Setup Procedure, Initial; 2-7, 4-5

Special Tools; 2-2, 4-2

Startup, Normal; 2-8, 4-6

Shutdown Procedure; 2-9, 4-7

Support Equipment; 2-2, 4-2

Symptom Index; 2-11, 4-9

T

Tools, Common; 2-1, 4-1

Tools, Special; 2-2, 4-2

TMDE; 2-2, 4-2

Troubleshooting; 2-11, 4-9

By Order of the Secretary of the Army:

CARL E. VUONO
General United States Army
Chief of Staff

Official:

WILLIAM J. MEEHAN, II
Brigadier General United States Army
The Adjutant General

DISTRIBUTION:

To be distributed in accordance with DA Form 12-25A, Unit and Direct Support and General Support Maintenance requirements for Landing Craft, Utility, LUC-1466, Type III.

* U. S. GOVERNMENT PRINTING OFFICE : 1993 0 - 342-421 (80407)

RECOMMENDED CHANGES TO EQUIPMENT TECHNICAL PUBLICATIONS



*THEN...JOT DOWN THE
DOPE ABOUT IT ON THIS FORM.
CAREFULLY TEAR IT OUT, FOLD IT
AND DROP IT IN THE MAIL.*

SOMETHING WRONG WITH PUBLICATION

FROM: (PRINT YOUR UNIT'S COMPLETE ADDRESS)

DATE SENT

PUBLICATION NUMBER

PUBLICATION DATE

PUBLICATION TITLE

BE EXACT PIN-POINT WHERE IT IS

PAGE
NO.

PARA-
GRAPH

FIGURE
NO.

TABLE
NO.

**IN THIS SPACE, TELL WHAT IS WRONG
AND WHAT SHOULD BE DONE ABOUT IT.**

PRINTED NAME, GRADE OR TITLE AND TELEPHONE NUMBER

SIGN HERE

The Metric System and Equivalents

Liquid Measure

Linear Measure

1 centiliter = 10 milliliters = .34 fl. ounce
 1 centimeter = 10 millimeters = .39 inch..... 1 deciliter = 10 centiliters = 3.38 fl. ounces
 1 decimeter = 10 centimeters = 3.94 inches..... 1 liter = 10 deciliters = 33.81 fl. ounces
 1 meter = 10 decimeters = 39.37 inches..... 1 dekaliter = 10 liters = 2.64 gallons
 1 dekameter = 10 meters = 32.8 feet..... 1 hectoliter = 10 dekaliters = 26.42 gallons
 1 hectometer = 10 dekameters = 328.08 feet..... 1 kiloliter = 10 hectoliters = 264.18 gallons
 1 kilometer = 10 hectometers = 3,280.8 feet

Square Measure

Weights

1 sq. centimeter = 100 sq. millimeters = .155 sq. inch
 1 centigram = 10 milligrams = .15 grain 1 sq. decimeter = 100 sq. centimeters = 15.5 sq. inches
 1 decigram = 10 centigrams = 1.54 grains..... 1 sq. meter (centare) = 100 sq. decimeters = 10.76 sq. feet
 1 gram = 10 decigram = .035 ounce..... 1 sq. dekameter (are) = 100 sq. meters = 1,076.4 sq. feet
 1 dekagram = 10 grams = .35 ounce..... 1 sq. hectometer (hectare) = 100 sq. dekameters = 2.47 acres
 1 hectogram = 10 dekagrams = 3.52 ounces..... 1 sq. kilometer = 100 sq. hectometers = .386 sq. mile
 1 kilogram = 10 hectograms = 2.2 pounds
 1 quintal = 100 kilograms = 220.46 pounds
 1 metric ton = 10 quintals = 1.1 short tons
 1 cu. centimeter = 1000 cu. millimeters = .06 cu. inch
 1 cu. decimeter = 1000 cu. centimeters = 61.02 cu. inches
 1 cu. meter = 1000 cu. decimeters = 35.31 cu. feet

...Cubic Measure

Approximate Conversion Factors

<i>To change</i>	<i>To</i>	<i>Multiply by</i>	<i>To change</i>	<i>To</i>	<i>Multiply by</i>
inches	centimeters	2.540	ounce-inches	newton-meters	.007062
feet	meters	.305	centimeters	inches	.394
yards	meters	.914	meters	feet	3.280
miles	kilometers	1.609	meters	yards	1.094
square inches	square centimeters	6.451	kilometers	miles	.621
square feet	square meters	.093	square centimeters	square inches	.155
square yards	square meters	.836	square meters	square feet	10.764
square miles	square kilometers	2.590	square meters	square yards	1.196
acres	square hectometers	.405	square kilometers	square miles	.386
cubic feet	cubic meters	.028	square hectometers	acres	2.471
cubic yards	cubic meters	.765	cubic meters	cubic feet	35.315
fluid ounces	milliliters	29.573	cubic meters	cubic yards	1.308
pints	liters	.473	milliliters	fluid ounces	.034
quarts	liters	.946	liters	pints	2.113
gallons	liters	3.785	liters	quarts	1.057
ounces	grams	28.349	liters	gallons	.264
pounds	kilograms	.454	grams	ounces	.035
short tons	metric tons	.907	kilograms	pounds	2.205
pound-feet	newton-meters	1.365	metric tons	short tons	1.102
pound-inches	newton-meters	.11375			

Temperature (Exact)

°F	Fahrenheit	5/9 (after	Celsius °C
temperature	subtracting 32)	temperature	

PIN : 065786 000